



ELEMENT DISPLAY

Operation, Calibration and Troubleshooting Manual



® by



Table of Contents

SECTION I: OPERATION.....	5
1.0 Outline of Operation	5
1.1 System Components.....	5
1.2 Display Unit.....	5
1.3 Reeling Drum Assembly.....	6
1.4 Pressure Transducers	6
1.5 Anti-Two Block (ATB).....	6
1.6 Function Kick-Out (FKO)	6
1.7 Operator Programmable Alarms	6
1.8 Outrigger Position Sensing	6
1.9 Electronic Frame-Level Sensor (If Equipped).....	7
2.0 System Self-Test	7
3.0 Start Up Screen.....	7
4.0 System Setup	8
4.1 Frame-Level Screen (If Equipped)	8
4.2 Accessing the Configuration Screen	11
5.0 The Configuration Screens	12
5.1 Pick Point	13
5.2 POL.....	14
5.3 Aux Head.....	15
5.4 Jib.....	16
5.5 Boom Mode	17
5.6 Stow.....	18
5.7 Counter Weight	19
5.8 Winch.....	20
5.9 Home	20
5.10 Next	21
5.11 Outrigger.....	21
5.12 Man Basket.....	22
5.13 Tires	22
5.14 Rigging Travel (Tires sub-menu).....	23
6.0 The Home Screen	24

6.1	Adjusting the Brightness of the Display	25
6.2	LMI Window	26
6.3	Crane Configuration Window	27
7.0	Cancel Alarm Button.....	28
7.1	Reset Function Kickout	28
8.0	Operator Programmable Alarms	29
8.1	Accessing the Operator Alarms	29
8.2	Setting Minimum Boom Angle Alarm.....	30
8.3	Setting Maximum Boom Angle Alarm	30
8.4	Setting Maximum Boom Length Alarm	31
8.5	Setting Maximum Tip Height Alarm	32
8.6	Swing Alarms	33
8.7	Accessing the Swing and Work Area Alarms	34
8.8	Setting the Swing Alarms.....	34
8.9	Work Area Selection Mode	35
8.10	Setting the Work Area Alarm	36
SECTION II: CALIBRATION & TROUBLESHOOTING		37
9.0	Introduction.....	37
9.1	Overview and Preparation.....	37
10.0	System Self-Test	38
11.0	Display Console Problems	39
12.0	Fault Reporting and Fault Codes	40
12.1	Group "A" Fault Codes.....	41
12.2	Group "B" Fault Codes.....	41
12.3	Group "C" Fault Codes.....	42
12.4	Group "D" Fault Codes	42
13.0	"No Fault Code" Problems.....	43
13.1	Anti-Two-Block Alarm (ATB).....	43
13.2	Displayed Load or Radius Errors.....	43
14.0	Computer Unit Overview.....	46
14.1	Internal Status Indicators	46
14.2	Function Kickout Fuse (FUS1).....	47
14.3	Replacing the Computer Unit	47
15.0	Display Console Overview	48

15.1	Checking the Display Console.....	48
15.2	Unresponsive Buttons	49
15.3	Connectors.....	49
15.4	Horn.....	50
15.5	Moisture	50
15.6	Replacing the Display Console.....	50
16.0	Entering the Calibration Mode	51
16.1	Calibration Steps.....	52
16.2	Calibration Menus	53
16.3	Calibrating the Extension Sensor Zero	54
16.4	Calibrating the Angle Sensor Zero	55
16.5	Calibrating Span of Extension and Angle.....	56
16.6	Calibrating the Swing Potentiometer	59
16.7	Calibrating the Outrigger Position Sensors	61
16.8	Calibrating the Frame-Level Sensor (If Equipped).....	64
16.9	After the Calibration Routine	66
17.0	Reeling Drum Overview.....	67
17.1	Checking the Reeling Drum Cable Layering.....	68
17.2	Sensor Baseplate Assembly	69
17.3	Anti-Two-Block Function Overview	71
17.4	Checking the Reeling Drum Cable	71
17.5	Checking the Anti-Two-Block Circuit	71
18.0	Swing Sensor Overview	73
18.1	Checking the Swing Sensor Drive Voltage	74
18.2	Checking the Swing Sensor Output Voltage	74
18.3	Checking the Swing Sensor Resistance.....	74
19.0	Frame-Level Sensor (If Equipped).....	75
20.0	Revision History	76

SECTION I: OPERATION

1.0 Outline of Operation



WARNING

The Greer LMI System is an operational aid that only provides information to the operator. It *is not* a load limiter, and it will not automatically prevent unsafe operations. The operator is solely responsible for operating the equipment consistent with the manufacturer's instructions and specifications, the equipment's rated capacity, applicable codes and laws, and industry safe practices.

Thoroughly review the Operation, Calibration and Troubleshooting Manual before operating the Greer LMI System.

FAILURE TO FOLLOW THE MANUAL AND OTHER MISUSE OF THIS PRODUCT CAN RESULT IN PROPERTY DAMAGE, SERIOUS INJURY, AND DEATH.

This manual describes the operation of the Greer Element, hereinafter referred to as the system. Please read the instructions contained in this manual.

1.1 System Components

- Display Unit
- Computer Unit with Integrated Pressure Transducers
- Reeling Drum Assembly, with Integrated Extension and Angle Sensors
- Anti-Two-Block Switch
- Cables
- Audible Alarm
- Installation/Operator Manual

1.2 Display Unit

The display unit provides the operator with:

- Rated Capacity
- Actual Load
- Bar graph representation of Actual Load vs. Rated Capacity
- Radius of the Load
- Boom Angle

- Main Boom Length
- Working Area
- Crane Configuration
- Frame-Level Sensor Screen, if equipped

1.3 Reeling Drum Assembly

The reeling drum assembly consists of the reeling drum and reeling drum cable, the boom angle sensor, and the extension sensor.

1.4 Pressure Transducers

There are two Pressure Transducers which measure pressure in the boom hoist cylinder. One sensor measures the rod-side pressure and one sensor measures the piston-side pressure. The Pressure Transducers are located in the computer unit.

1.5 Anti-Two Block (ATB)

A switch monitors the approach of the hook block or overhaul ball to the boom head. The switch is held in the normal position until the hook block or overhaul ball raises a weight that is mounted around the hoist rope. When the weight is raised it opens the switch. The resultant signal is sent to the computer via the reeling drum causing an ATB alarm and function kick-out to occur.

1.6 Function Kick-Out (FKO)

Electrically-operated hydraulic solenoids disable the functions for boom hoist lower, telescope out, and winch up when an overload or ATB alarm condition occurs.

1.7 Operator Programmable Alarms

These alarms, when properly set by the operator, define the operating range. These alarms are programmable for each job site and allow the operator to work in a defined area.

- Minimum Boom Angle Alarm
- Maximum Boom Angle Alarm
- Maximum Boom Length Alarm
- Maximum Tip Height Alarm
- Left and Right Swing Alarm
- Work Area Alarm

1.8 Outrigger Position Sensing

This alarm alerts the operator, audibly and visually, when the selected outrigger position does not match the detected outrigger position.

1.9 Electronic Frame-Level Sensor (If Equipped)

This sensor and display screen, show the cranes position on the X-axis and Y-axis relative to the 0.0° preset at the factory.

2.0 System Self-Test

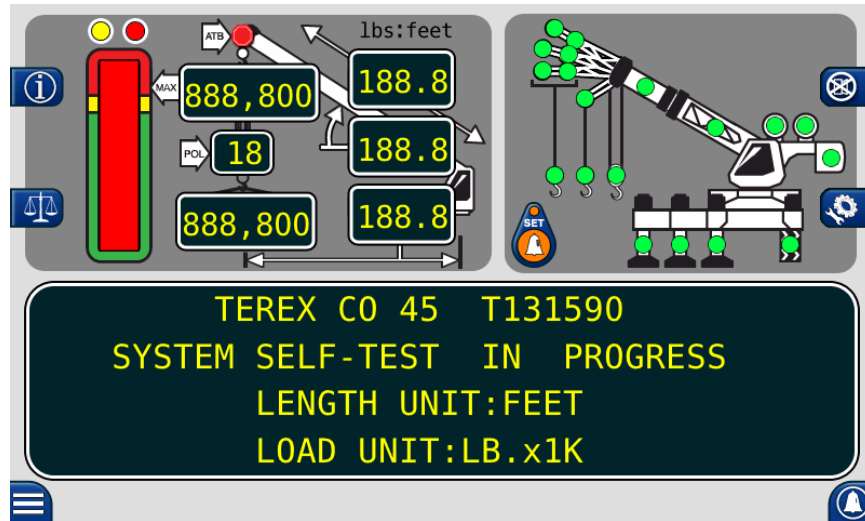

NOTE: Display message is crane dependent. This is only an example.

Immediately following electrical power up or entering calibration mode, the system executes a self-test lasting approx. 10 seconds.

During this time the numerical display segments and bar graph segments are all turned on, the audible alarm will sound an alarm indicator lights are illuminated.

3.0 Start Up Screen

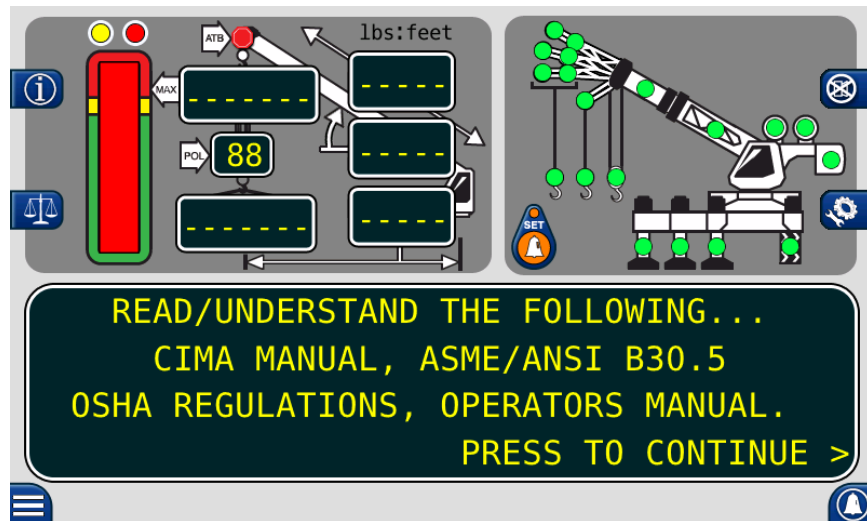

Immediately following the power up self-test, the display will show as above. During this time, the crane is disabled by the system function kick-out. Press the **Press to Continue** button to acknowledge the home display message and allow the system to start normal operation.

4.0 System Setup

4.1 Frame-Level Screen (If Equipped)

If the machine is equipped with a Frame-Level sensor, press the **Menu** button to access the Menu screen. **NOTE:** This option will not appear on machines without a Frame-Level sensor installed.



Use the Frame-Level screen to ensure the machine is properly leveled.

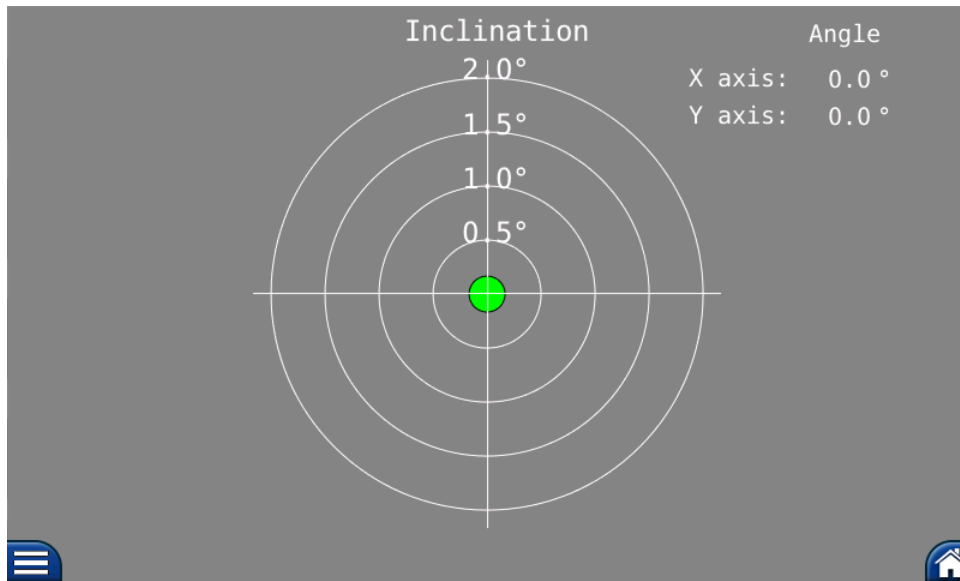

Machine angle from level	Dot Indicator
0°-0.9° on either axis	Green
1°-1.9° on either axis	Yellow
2°+ on either axis	Red

If the Frame-Level sensor, or its connection, malfunctions the home screen grid will display in red.

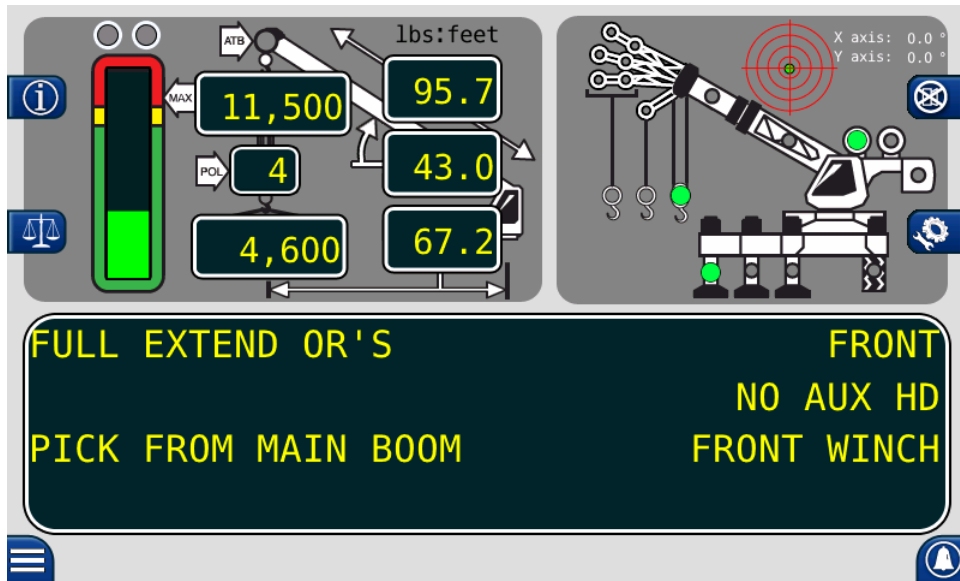

The grid on the Frame-Level screen will also display in red.

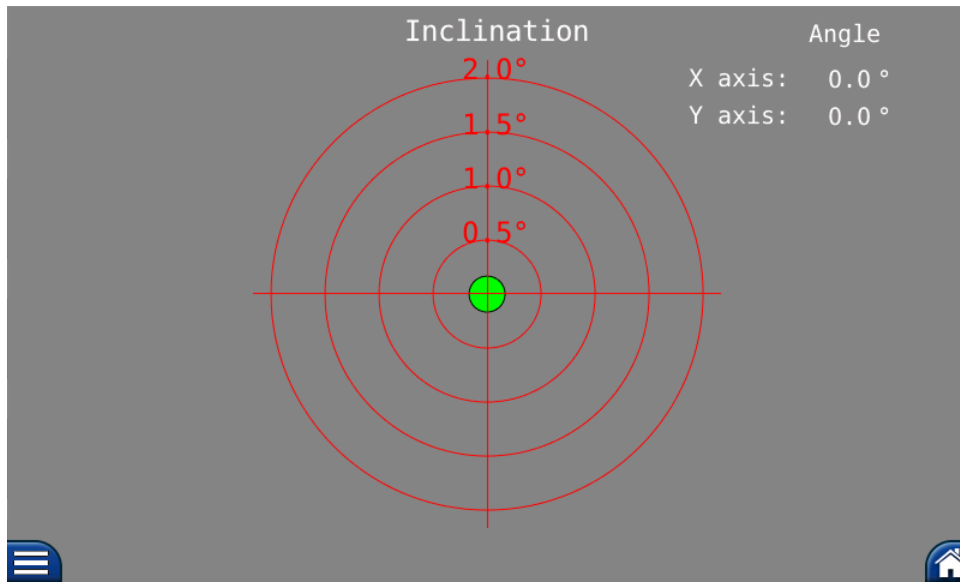

To exit the screen, press the **Home** button in the lower right corner.

4.2 Accessing the Configuration Screen



NOTE: Press the **Configuration** button to access the **Configuration** screen.

The system will remember all previously set data, including after the system is powered off and powered on.

After the configuration has been set, the operator must choose the winch in use. Changing the winch will automatically change the lifting point and the parts of line to the previously set data for the selected winch.

NOTE: Always check the point of lift and parts of line following selection of the winch.



WARNING! THE DISPLAYED LOAD AND CAPACITY ARE BASED UPON THE CURRENT SELECTED POINT OF LIFT. NEITHER THE GREER ELEMENT SYSTEM OR THE CRANE CAPACITY CHART ALLOWS FOR LIFTING FROM MORE THAN ONE HOOK AT A TIME.

5.0 The Configuration Screens

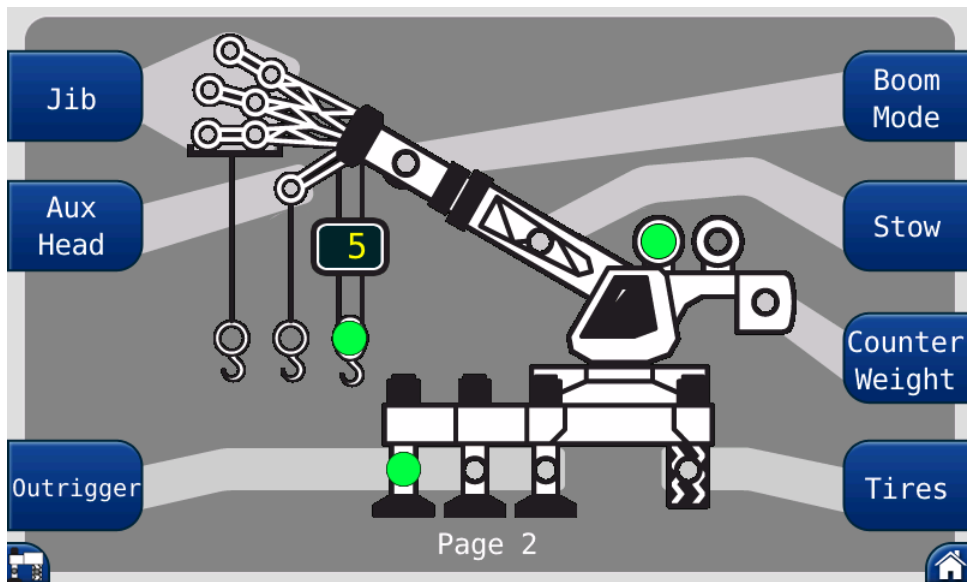
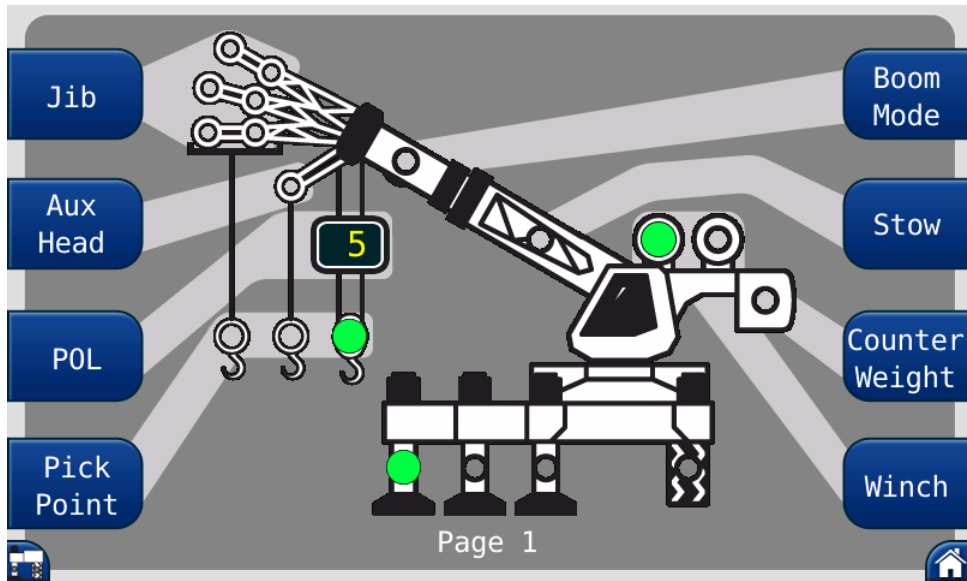

The **CONFIGURATION** screens represent the current setup of the system with green indicators. Each area contains a group of one or more green indicators and a button to change the setup selection.

5.1 Pick Point

The **Pick Point** button contains three green indicators. A single green indicator will illuminate to show the point of lift. Press the **Pick Point** button to scroll through the available options.

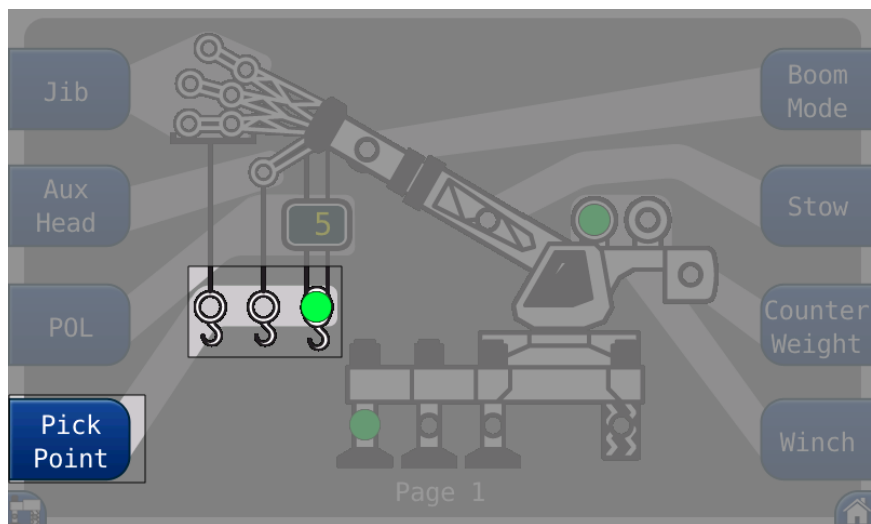

5.2 POL

The **POL** button (Parts of Line) changes the current number of parts of line in use.



5.3 Aux Head

Press the **Aux Head** button when the aux head is fitted.

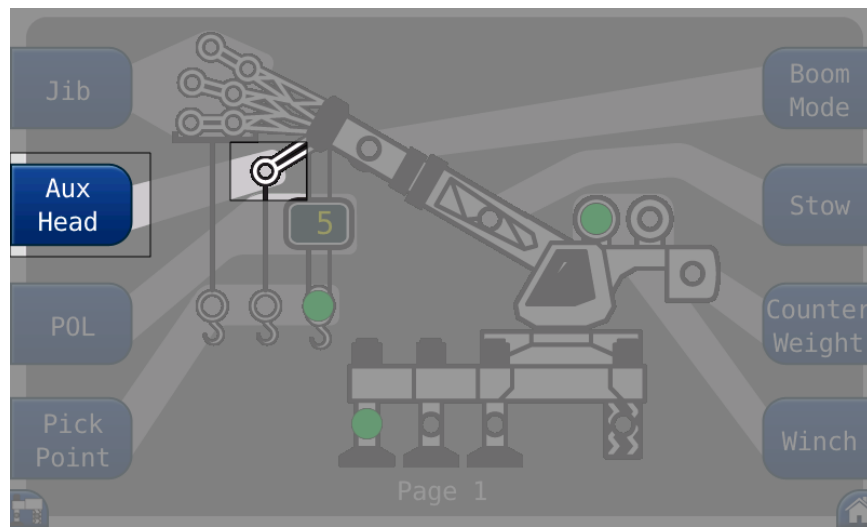

5.4 Jib

Press the **Jib** button to access the different options. The **Jib** group contains 6 green indicators. They indicate the length and offset of the jib in use.

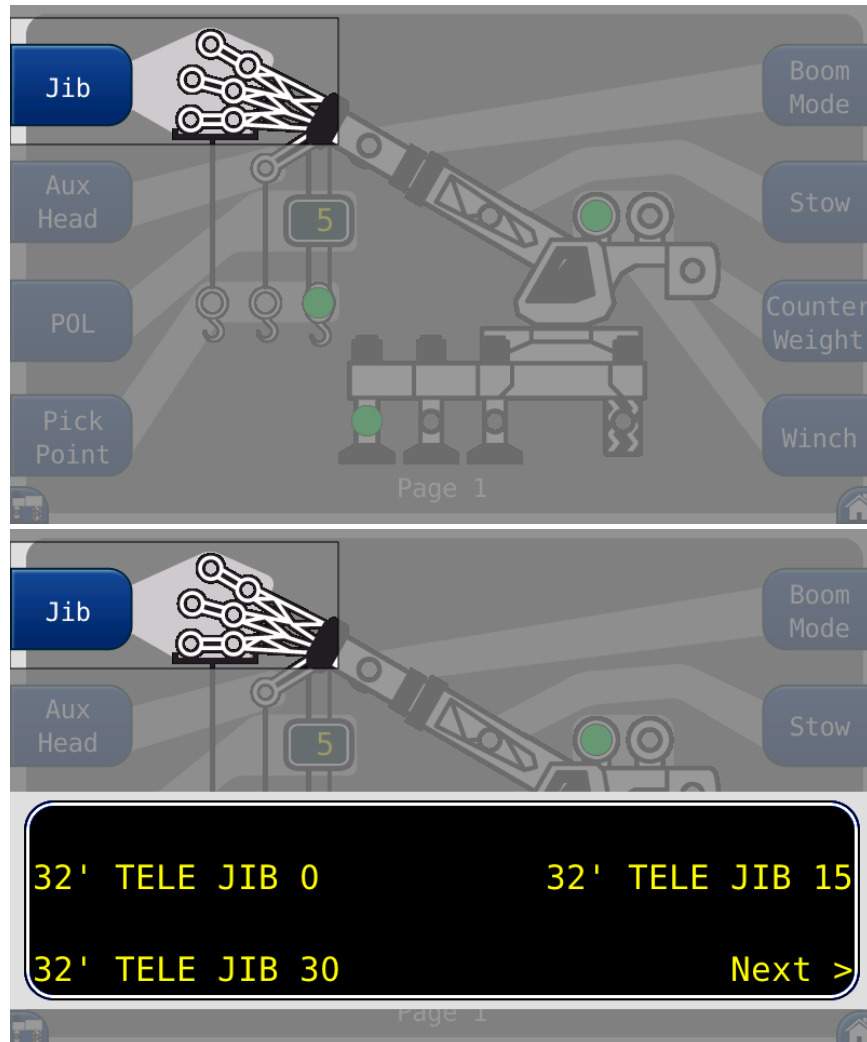

5.5 Boom Mode

The **Boom Mode** group contains one green indicator for machines with pinned extensions or active boom tip options. Choose the boom mode in use.

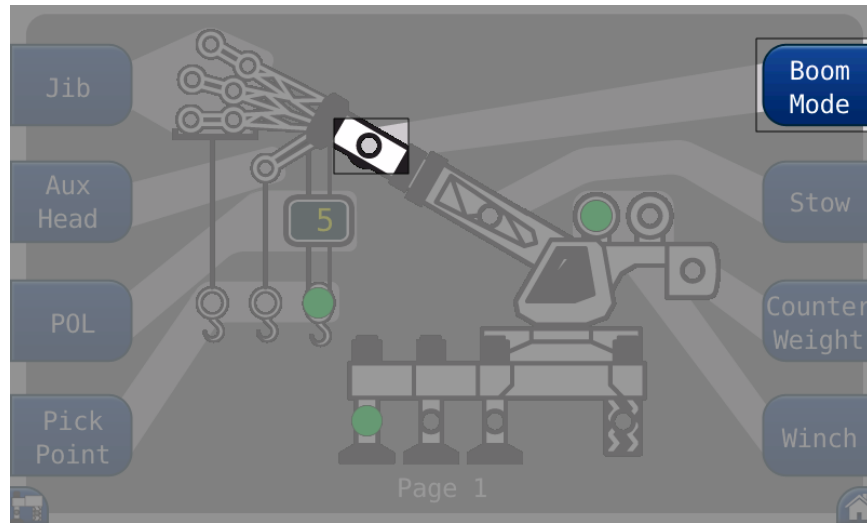

5.6 Stow

The **Stow** (Stowed Jib) group indicator illuminates when a jib is stowed on the boom.



5.7 Counter Weight

The **Counter Weight** group contains one green indicator. It is only active on machines equipped with counterweight options.



5.8 Winch

The **Winch** group contains two green indicators, which indicate the front or rear winch. The **Winch** button toggles between the two options.

NOTE: If the crane is equipped with two winches, always select the winch to be used for the lift prior to the point of lift and parts of line

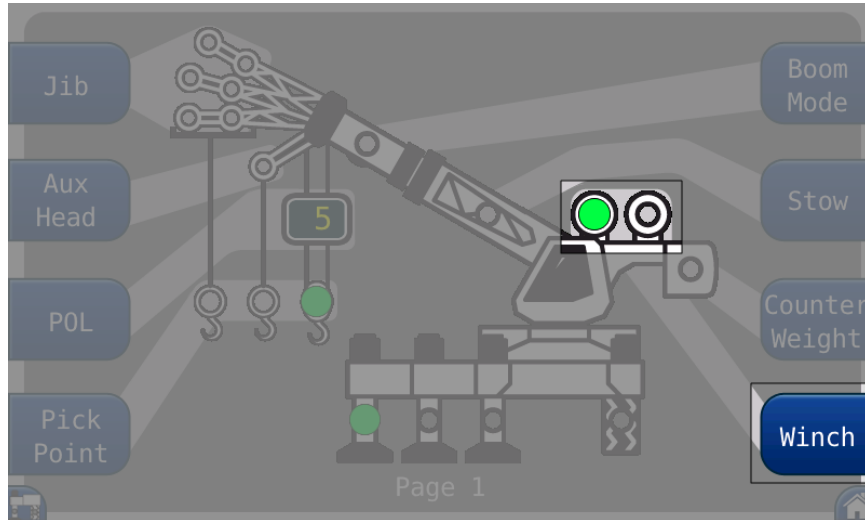

5.9 Home

The **Home** button returns the display to the Home screen. This is the same for both configuration pages.

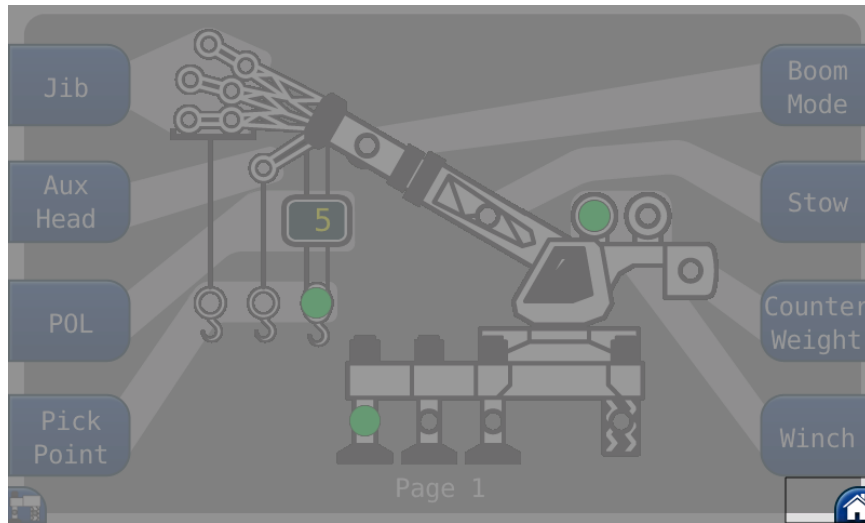

5.10 Next

The **Next** button, in the lower left, will toggle between the two Configuration screens.

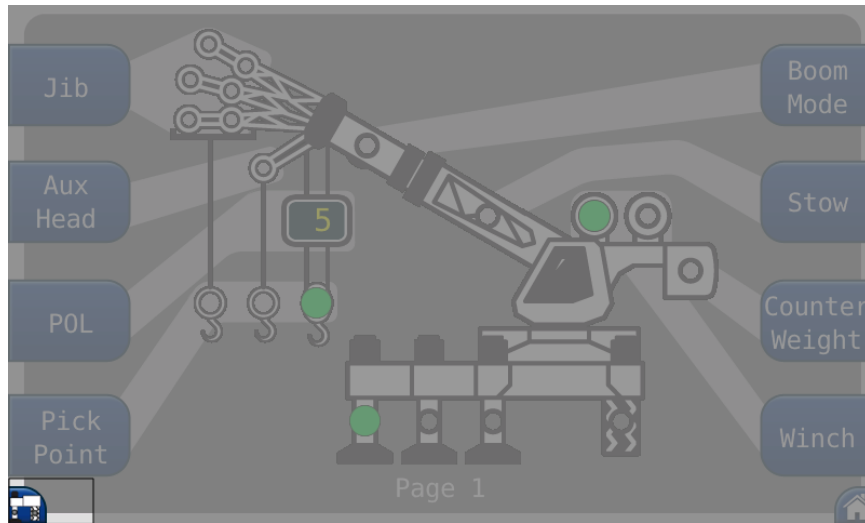

5.11 Outrigger

The **Outrigger** button contains three green indicators. They indicate full, intermediate, or retracted outriggers. Ensure the selection matches the current crane setup. Each button press will cycle through the available options.

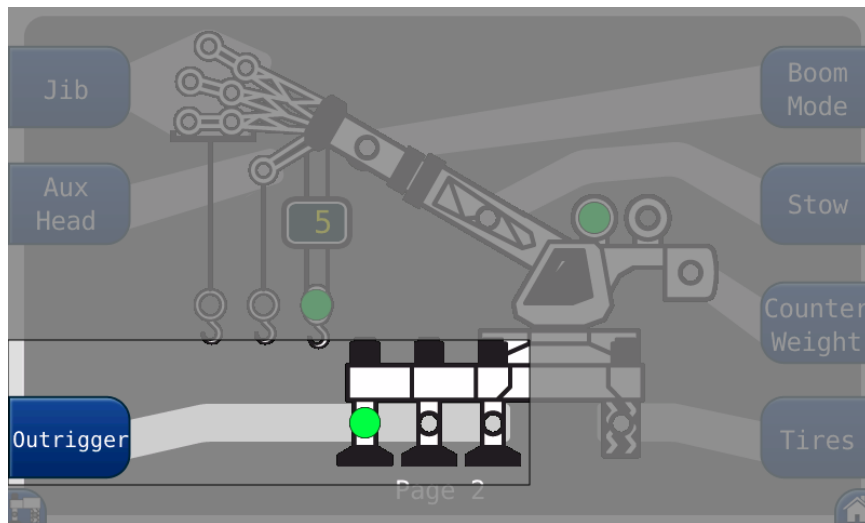

Outrigger Position Sensing (If Equipped)

The operator will be warned if the selected outrigger position does not match the detected outrigger position.

Correct Selection: The selection will have a solid green indicator, when the selected and detected outrigger positions match.

Incorrect Selection: The detected position will flash a red indicator and the selected position will be a solid yellow indicator. On the main screen, an audible alarm will sound if the selected position is greater than the detected position. The alarm will sound if the operator has selected fully extended outriggers, but the outriggers are in the intermediate or fully retracted position.

5.12 Man Basket

The **Man Basket** button enables the optional Personnel Platform, if equipped.

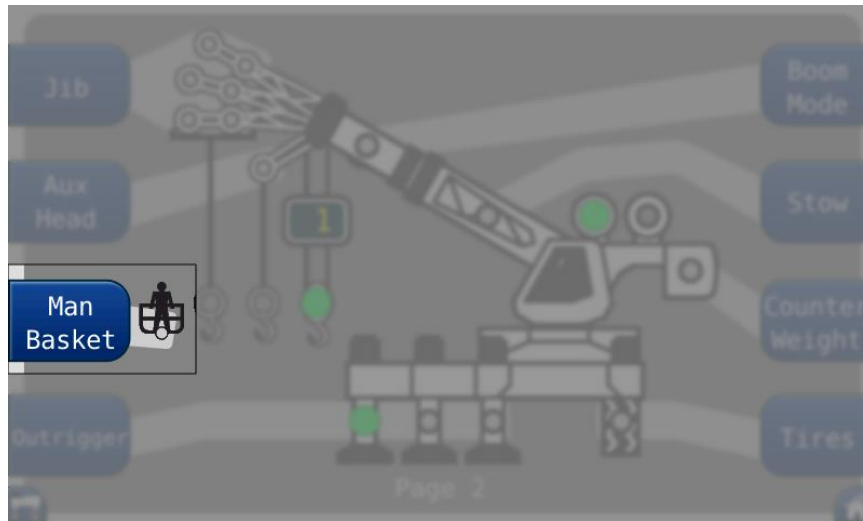

5.13 Tires

Press the **Tires** button to access the tire selection screen. The **Tires** group contains one green indicator. Choose the correct setting to be used. For machines with more than one tire option, it is important the operator selects the tire configuration for the tire chart used.

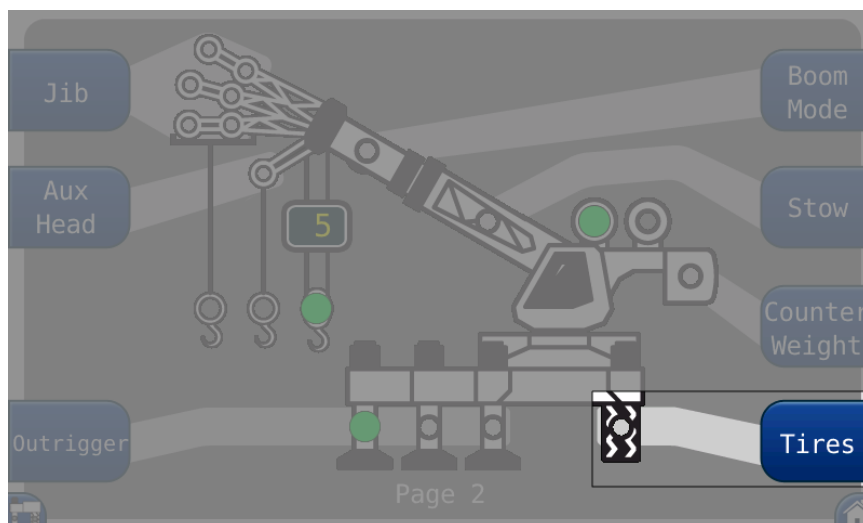

5.14 Rigging Travel (Tires sub-menu)

After selecting **Tires**, select RIGGING/TRAVEL mode when the machine is in the rigging process or is a rough terrain crane traveling between jobs. When in RIGGING/TRAVEL mode all other functions are disabled.

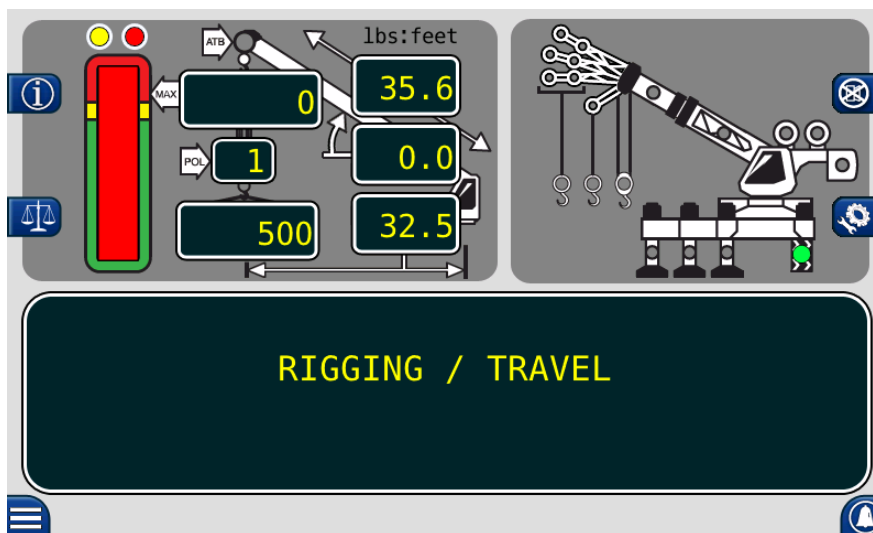
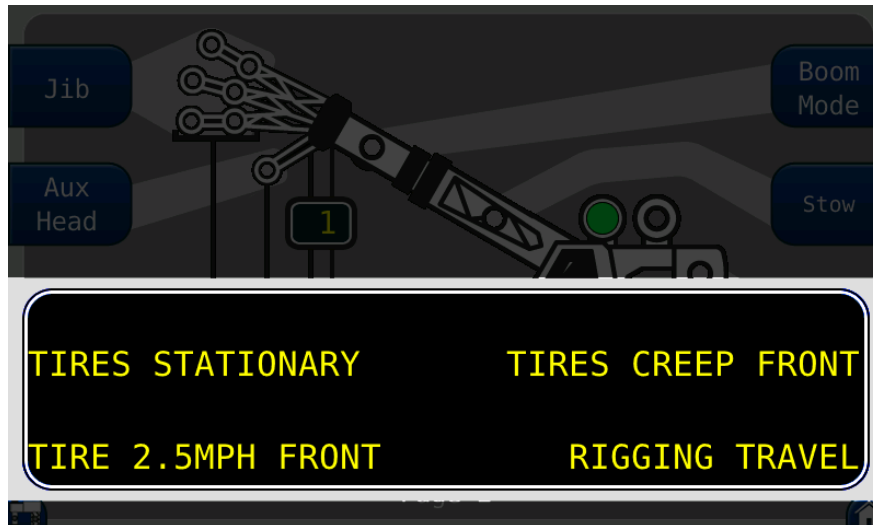

6.0 The Home Screen

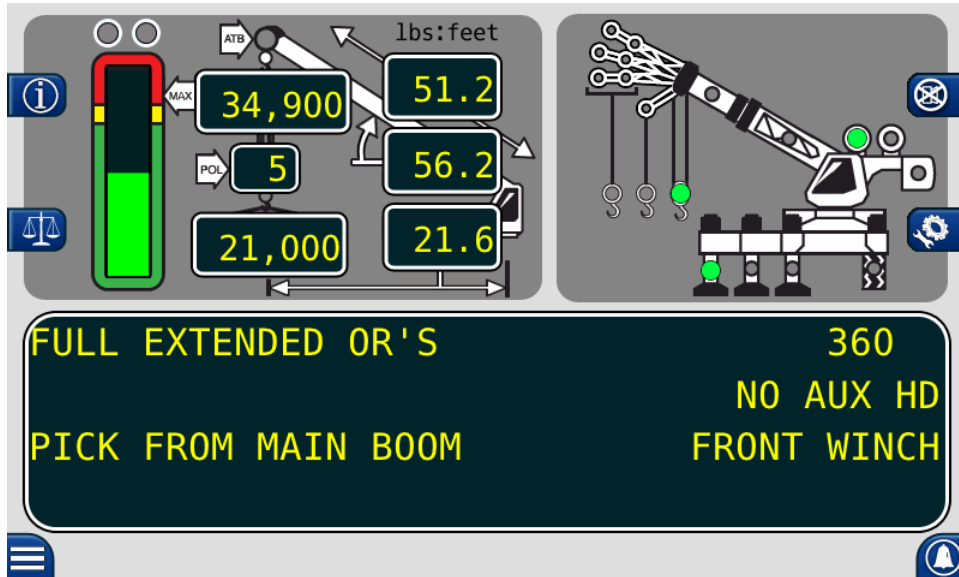

The Home screen shows the LMI window, Crane Configuration window, and the Information Window. The LMI window is the upper left portion of the screen and displays information such as Actual Load, Angle, Load Radius, etc. The Crane Configuration window provides a pictorial representation of the current crane setup. The Information window provides a text representation of the Crane Configuration including the Load Chart in use and error codes.

6.1 Adjusting the Brightness of the Display

1. Press the **Menu** button to access the **Menu** screen.
2. Press the **Brightness** button.



3. Then adjust the display to match the current conditions.



4. Press **Exit** when finished. The display will return to the **Menu** screen.

6.2 LMI Window

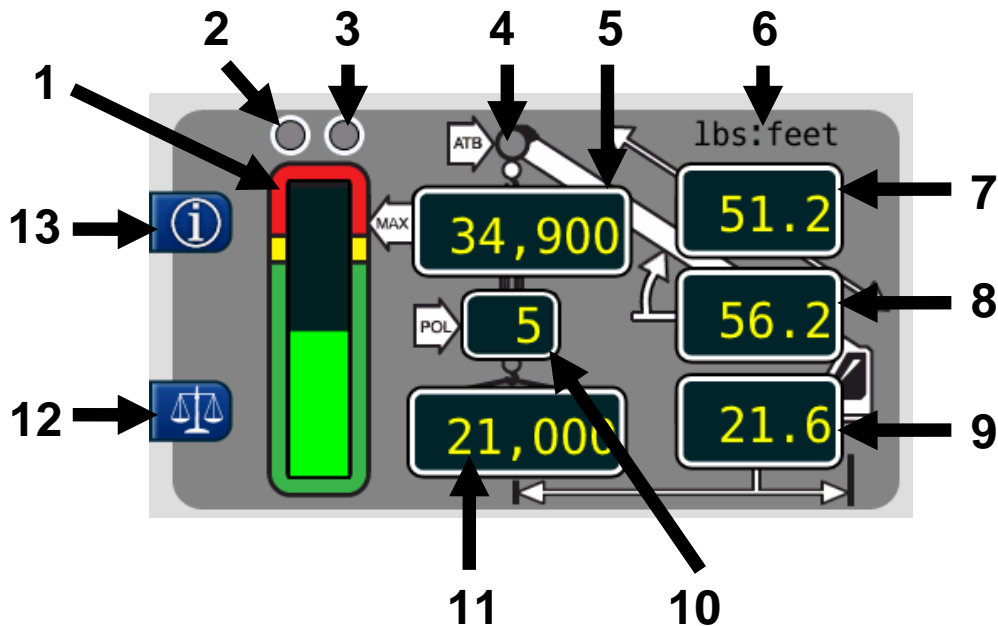

1. **BAR GRAPH** – This displays the **ACTUAL LOAD** relative to the **RATED CAPACITY**.
2. **PRE-ALARM INDICATOR** – This yellow indicator illuminates at 90% of the **RATED CAPACITY** to provide a visual indication of approaching overload.
3. **OVERLOAD INDICATOR** – This red indicator illuminates at 100% of the **RATED CAPACITY** to provide a visual indication of maximum load.
4. **ANTI-TWO-BLOCK** – This red indicator illuminates when the **ATB** switch detects an approach to a two-block condition.
5. **RATED CAPACITY** – This displays the maximum capacity of the crane in the current configuration.
6. **LOAD CHART INDICATOR** – The **lbs:feet** text indicates use of the Imperial load chart and **kgs:m** indicates use of the Metric load chart.
7. **BOOM EXTENSION** – This displays the current extended length of the boom.
8. **BOOM ANGLE** – This displays the current angle of the boom relative to horizontal.
9. **LOAD RADIUS** – This displays the current radius of the load.
10. **PARTS OF LINE** – This displays the current selection for parts of line.
11. **ACTUAL LOAD** – This displays the total load suspended below the lifting point including slings, hooks, etc.
12. **CALIBRATION BUTTON** – This button accesses the Calibration Key Sequence screen.
13. **INFORMATION BUTTON** – Press and hold this button to display the current duty chart, main program, and any fault codes present.

6.3 Crane Configuration Window

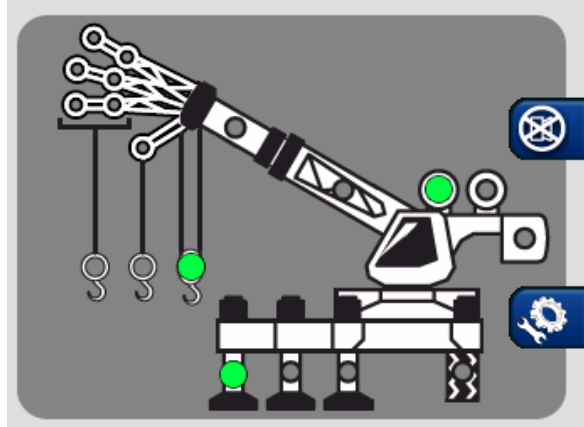

The **Crane Configuration** window on the **Home** screen provides a graphical representation of the current Crane Configuration. The green indicators show the specifics of the crane setup. In this example, the crane is:

- Using the main boom as the pick point.
- Using the front winch.
- Using fully extended outriggers.

Information Window

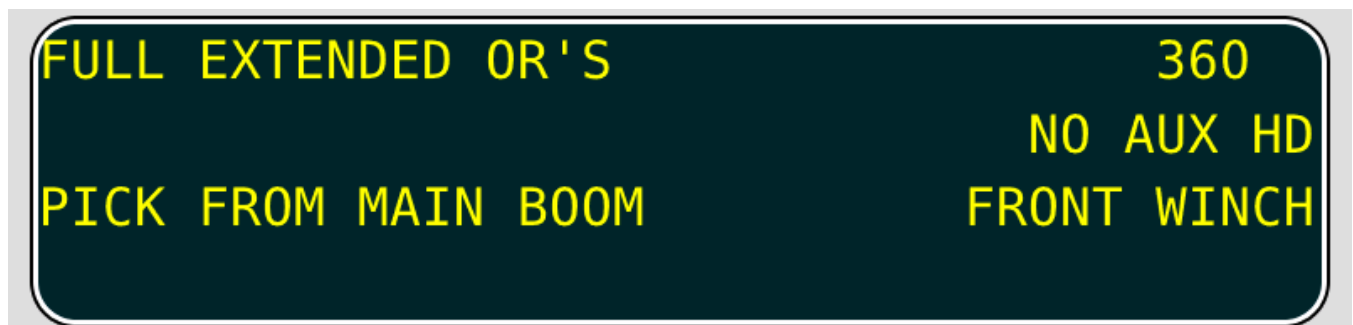

The Information window displays information on the current **Crane Configuration**, **Menu Screens**, **Alarm Warnings**, and **Fault Codes**.

7.0 Cancel Alarm Button



The **CANCEL ALARM** button is used to silence the audible alarm. Pressing the button once will cancel an audible alarm caused by an:

- Overload
- ATB Alarm
- Operator Programmable Alarm
- Outrigger Horizontal Position Match

The audible alarm will remain cancelled until the condition causing the alarm has been resolved.

7.1 Reset Function Kickout

When rigging the machine, it may be necessary to place the boom in a position that could cause a function kick-out (FKO). In this situation, press the **Cancel Alarm Button**.

Press and hold the **Cancel Alarm Button** for approximately 10-15 seconds to reset the relay. A second beep will confirm the bypass. When the condition which caused the FKO is no longer present, the function disconnect relay will reset to the normal condition. If a different alarm condition occurs while the relay is over-riden, the new alarm condition will cause another FKO.



WARNING! WHEN THE FUNCTION DISCONNECT RELAY IS RESET USING THE CANCEL ALARM BUTTON, THERE IS NO LONGER PROTECTION AGAINST THE CONDITION THAT CAUSED THE FUNCTION KICK-OUT.

8.0 Operator Programmable Alarms

8.1 Accessing the Operator Alarms

Press the **Operator Alarm** button from the **Home** screen to access the operator alarms. The information screen will show the current status of the operator alarms.



There are four buttons to the left and right of the **Information** window. Each button relates to the indicated alarm. In addition, each operates as a toggle switch. If the alarm to be set is OFF, press the button to turn the alarm ON. If the alarm to be set is ON, press the button to turn the alarm OFF.

When the **Operator Alarms** are set, the alarm set icon will appear.

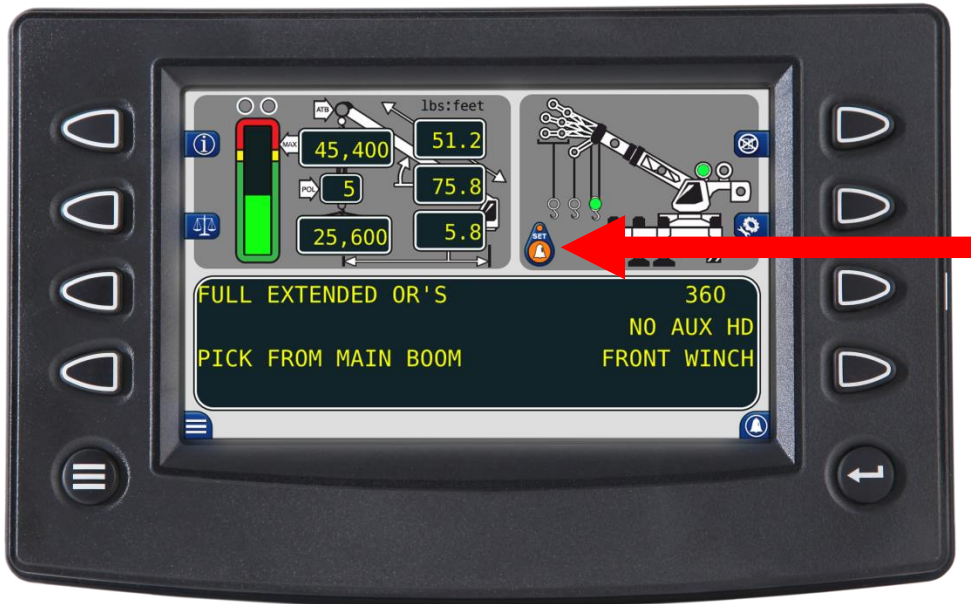

Operator Programmable Alarms

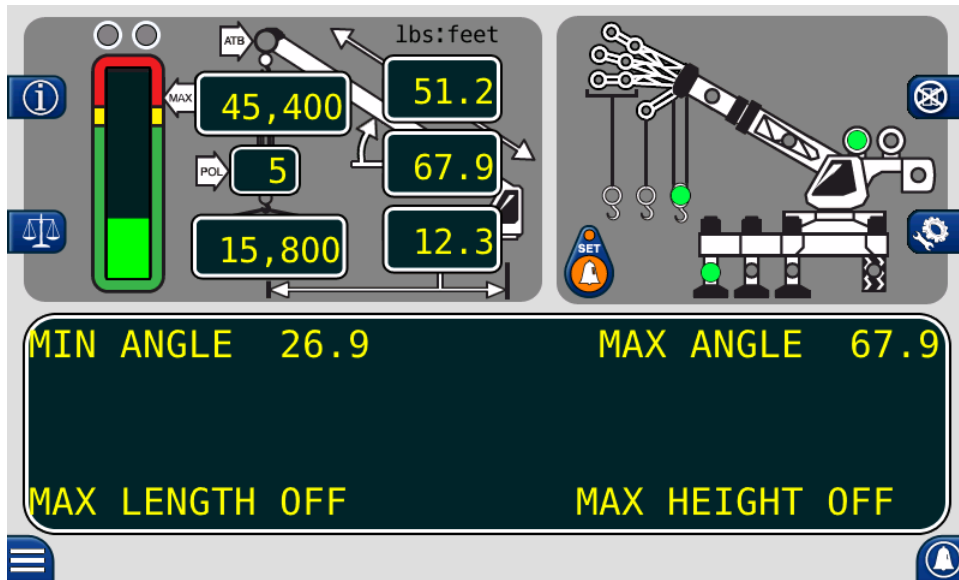

8.2 Setting Minimum Boom Angle Alarm

1. Move the boom to the desired minimum angle, in this example, 26.9°.
2. Press the **Operator Alarm** button to access the **Operator Alarm** screen.
3. Press the **MIN ANGLE** button. In this example, the screen will read **MIN ANGLE 26.9**.
4. The red warning light will flash and the alarm will sound when the boom angle is below 26.9°.
5. Press the **MIN ANGLE** button to cancel the alarm. The screen will read **MIN ANGLE OFF**.

8.3 Setting Maximum Boom Angle Alarm

1. Move the boom to the desired maximum angle, in this example 67.9°.
2. Press the **Operator Alarm** button to access the **Operator Alarm** screen.
3. Press the **MAX ANGLE** button. In this example the display will read **MAX ANGLE 67.9**.
4. The red warning light will flash and the alarm will sound whenever the boom angle is above 67.9°.
5. Press the **MAX ANGLE** button to cancel the alarm. The display will read **MAX ANGLE OFF**.

Operator Programmable Alarms

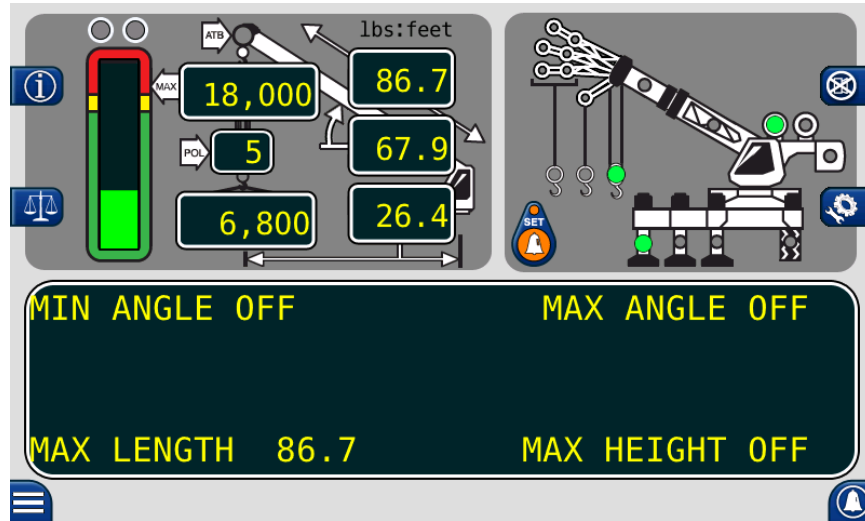

8.4 Setting Maximum Boom Length Alarm

1. Move the boom to the desired maximum length, in this example 86.7 ft.
2. Press the **Operator Alarm** button to access the **Operator Alarm** screen.
3. Press the **MAX LENGTH** button. In this example the display will read **MAX LENGTH 86.7**.
4. The red warning light will flash and the alarm will sound whenever the boom length exceeds 86.7 ft.
5. Press the **MAX LENGTH** button to cancel the alarm. The display will read **MAX LENGTH OFF**.

Operator Programmable Alarms

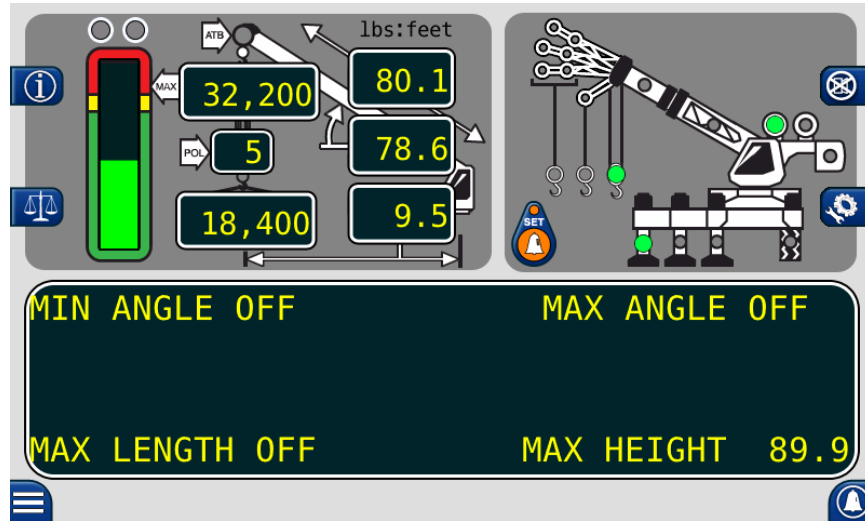

8.5 Setting Maximum Tip Height Alarm

1. Move the boom tip to the desired maximum height, in this example, 89.9 ft.
2. Press the **Operator Alarm** button to access the **Operator Alarm** screen.
3. Press the **MAX HEIGHT** button. In this example the display will read **MAX HEIGHT 89.9**.
4. The red warning light will flash and the alarm will sound whenever the boom tip height exceeds 89.9ft.
5. Press the **MAX HEIGHT** button to cancel the alarm. The display will read **MAX HEIGHT OFF**.

Operator Programmable Alarms

8.6 Swing Alarms

These alarms permit the operator to define a Working Arc and an Exclusion Zone by two set points. The following diagram illustrates the Working Arc and Exclusion Zone.

A left swing alarm is activated when swinging to the left.

A right swing alarm is activated when swinging to the right.

In this example the working arc is the smaller piece of the pie.

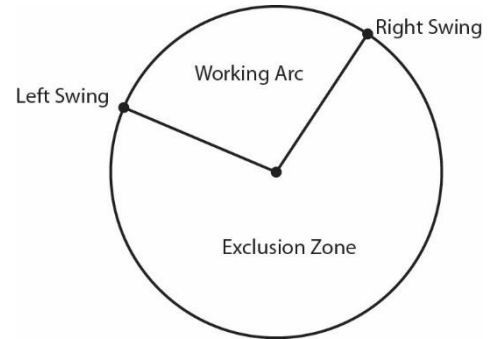

A left swing alarm is activated when swinging to the left.

A right swing alarm is activated when swinging to the right.

In this example the working arc is the larger piece of the pie.

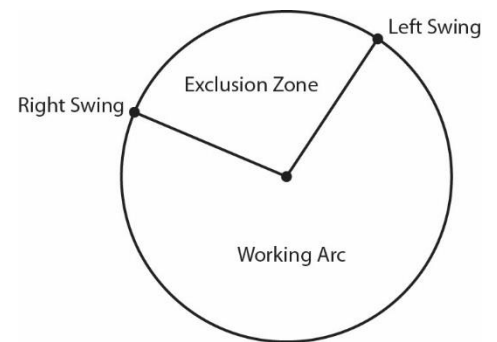

WARNING! THE OPERATOR DEFINED SWING ALARM IS A WARNING DEVICE. ALL FUNCTIONS REMAIN OPERATIONAL WHEN ENTERING THE OPERATOR DEFINED EXCLUSION ZONE. IT IS THE RESPONSIBILITY OF THE OPERATOR TO SET SWING ALARMS THAT ENSURE THE CRANES BOOM, ATTACHMENT, LOAD, RIGGING, ETC. MAINTAIN A SAFE WORKING DISTANCE FROM THE OBSTACLE.

AVOID POSITIONING THE BOOM, ATTACHMENT, LOAD, RIGGING ETC. IN THE EXCLUSION ZONE WHEN MOVING TO THE LEFT AND RIGHT SWING POINTS. WHEN SELECTING LEFT AND RIGHT SWING POINTS ENSURE THE LOAD WILL MAINTAIN A SAFE DISTANCE FROM THE OBSTACLE. RESET THE SWING ALARMS IF THE CRANE OR OBSTACLE IS MOVED OR IF A DIFFERENT SIZE LOAD IS LIFTED.

Operator Programmable Alarms

8.7 Accessing the Swing and Work Area Alarms

Access the swing and work area alarms from the main working screen by pressing the **Operator Alarm** button twice.

The information window will show the current status of the swing and work area alarms. There are four buttons, one for each alarm.

Each button operates as a toggle switch.

- If the alarm is OFF, pressing the button will turn the alarm ON.
- If the alarm is ON, pressing the button will turn the alarm OFF.
- When **Operator Alarms** are set the icon will appear.
- Return to the main screen by pressing the **Operator Alarm** button.

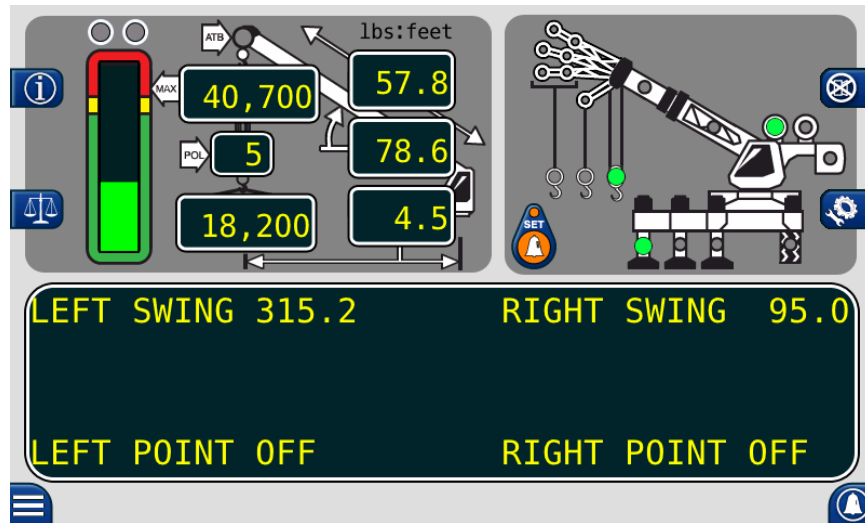

8.8 Setting the Swing Alarms

NOTE: The Left and Right Swing Alarms must be set for the alarm to operate correctly. The red warning indicator will flash and the alarm will sound whenever only one of the swing limits is set.

1. Swing the boom to the desired left swing limit, for example, 315.2°.
2. Press the **Operator Alarm** button twice to access the swing alarm screen.
3. Press the **LEFT SWING** button. The display will read **LEFT SWING** 315.2.
4. Move the boom to the desired right swing limit, for example, 95°.
5. Press the **RIGHT SWING** button. The display will read **RIGHT SWING** 95.

The red warning indicator will flash and the alarm will sound whenever the boom swings past the preset limits. Pressing the **LEFT SWING** and **RIGHT SWING** buttons again will cancel the alarm and the display will read **LEFT SWING OFF** **RIGHT SWING OFF**.

Operator Programmable Alarm

8.9 Work Area Selection Mode

This alarm permits the operator to define an Operating Zone by only two set points. The use of this method of results in an enhanced working area and defines the Exclusion Zone area more simply. The following diagram illustrates the Operating Zone and the Exclusion Zone.

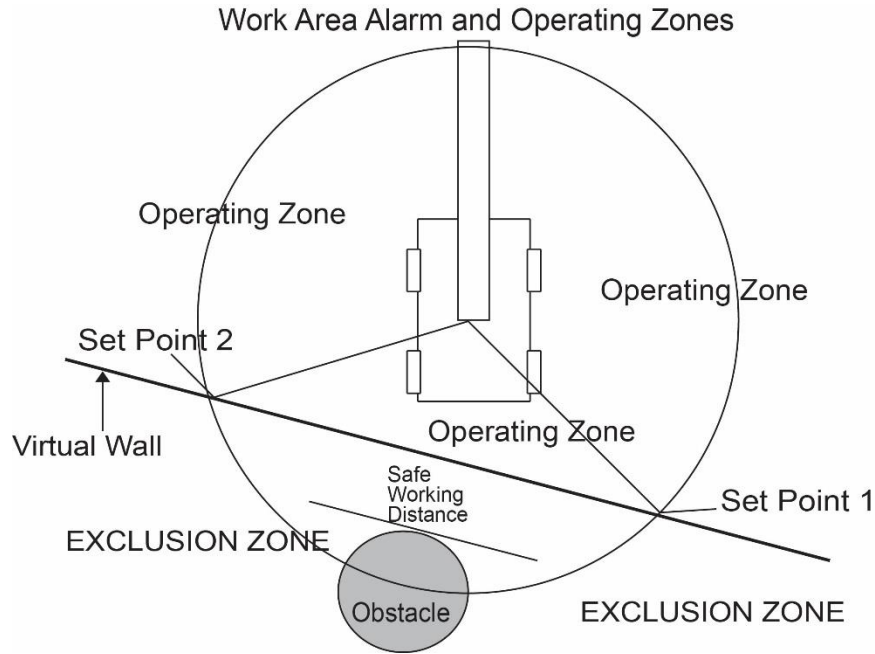

The operator defined work area alarm will define an imaginary vertical plane between two set points. When passing the plane the red warning lamp will illuminate, the alarm will sound and the message "EXCLUSION ZONE" will flash on the display.



WARNING! THE OPERATOR DEFINED WORK AREA ALARM IS A WARNING DEVICE. ALL FUNCTIONS REMAIN OPERATIONAL WHEN ENTERING THE OPERATOR DEFINED EXCLUSION ZONE. "SAFE WORKING DISTANCE" IS THE TIME IT WOULD TAKE AN OPERATOR TO REACT TO AN ALARM AND FOR THE MACHINE MOTION TO BE HALTED BEFORE ENTERING THE EXCLUSION ZONE. IT IS THE RESPONSIBILITY OF THE OPERATOR TO SET POINTS THAT ENSURE THAT THE CRANES BOOM, ATTACHMENT, LOAD, RIGGING ETC. MAINTAINS A SAFE WORKING DISTANCE FROM THE OBSTACLE.

Do not position the boom, attachment, load, rigging etc. in the Exclusion Zone when moving to Set Points 1 and 2. When selecting the Left Points and Right Point, ensure the load will maintain a safe distance from the obstacle. Reset the work area alarm, if the crane or obstacle is moved, or if a different size load is lifted.

Operator Programmable Alarms

8.10 Setting the Work Area Alarm

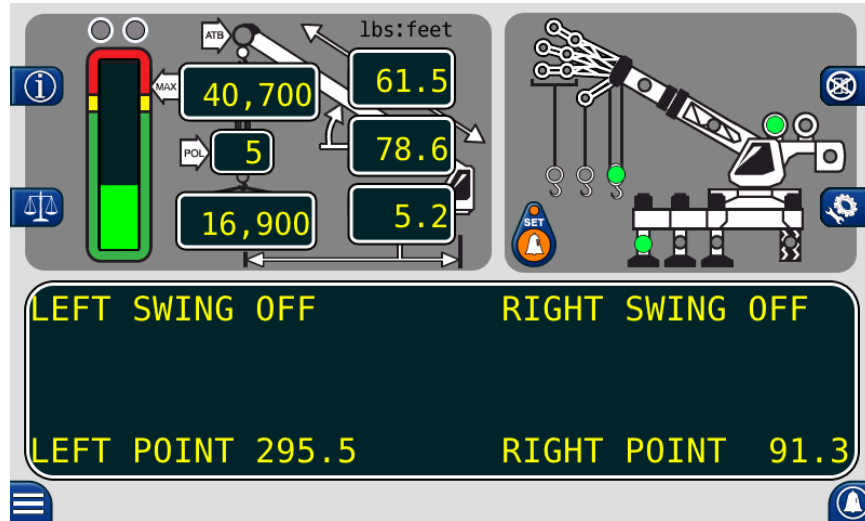

1. Press the **Operator Alarm** button twice to access the **Work Area** alarm screen.
2. Move the boom, attachment, load, rigging etc. to the desired **LEFT SET POINT**.
3. Press the **LEFT POINT** button. The display will read **LEFT POINT SET**.

NOTE: The Left and Right Points must be set for the system to operate correctly. The red warning light will flash and the audible alarm will sound whenever only one of the left/right swing limits is set.

4. Move the boom, attachment, load, rigging etc. to the desired **RIGHT SET POINT**.
5. Press the **RIGHT POINT** button. The display will read **RIGHT POINT SET**.
6. The red warning light will flash and the audible alarm will sound whenever the boom tip penetrates the exclusion zone.
7. Pressing the **LEFT POINT** and **RIGHT POINT** buttons again will cancel the alarm and the display will read **LEFT POINT OFF** **RIGHT POINT OFF**.

SECTION II: CALIBRATION & TROUBLESHOOTING

9.0 Introduction



WARNING

The Greer LMI System is an operational aid that only provides information to the operator. It *is not* a load limiter, and it will not automatically prevent unsafe operations. The operator is solely responsible for operating the equipment consistent with the manufacturer's instructions and specifications, the equipment's rated capacity, applicable codes and laws, and industry safe practices.

Thoroughly review the Operation, Calibration and Troubleshooting Manual before operating the Greer LMI System.

FAILURE TO FOLLOW THE MANUAL AND OTHER MISUSE OF THIS PRODUCT CAN RESULT IN PROPERTY DAMAGE, SERIOUS INJURY, AND DEATH.

This manual describes the setup and maintenance of the system. Please read the instructions in this manual.

9.1 Overview and Preparation

This manual provides general information and methods for isolating problems which may occur during operation. Service personnel should have previous training and experience in the procedure for setup and operation of this system. Some problems may require the replacement of parts or the return of parts to the factory for servicing.

The procedures in this manual are based on crane operation and function, where possible. Required tools:

- Tool kit consisting of wrenches and screwdrivers (flat and Phillips)
- Digital level accurate to 0.1°
- 150-200 ft tape measure graduated in tenths of a foot
- Digital multimeter

NOTE: *Low cost analog multimeters are not appropriate; their input impedance may give inaccurate readings.*

10.0 System Self-Test

When the power is turned on, the system performs a self-test. This verifies the computer, display console, cable, and sensors are working properly. During the self-test, the display will show the expected crane model, load chart number, and units of measurement.

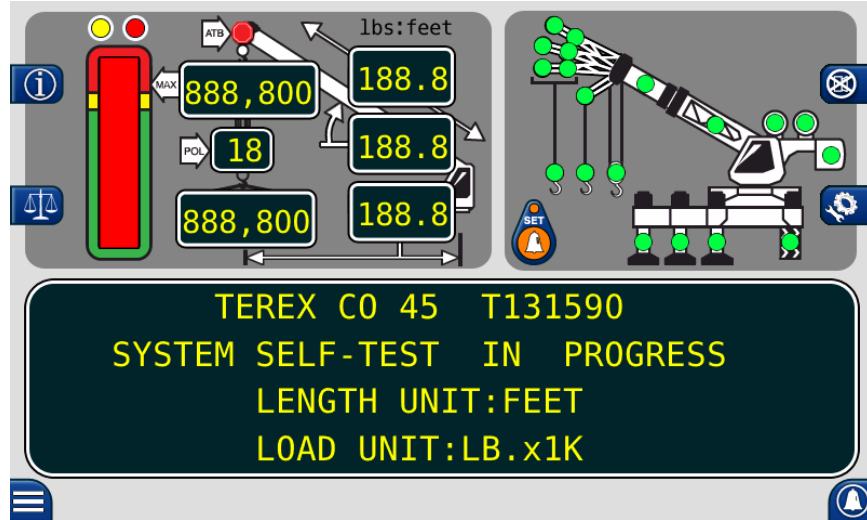

NOTE: Display message is crane dependent

Press the **PRESS TO CONTINUE** button to access the **Home** screen.

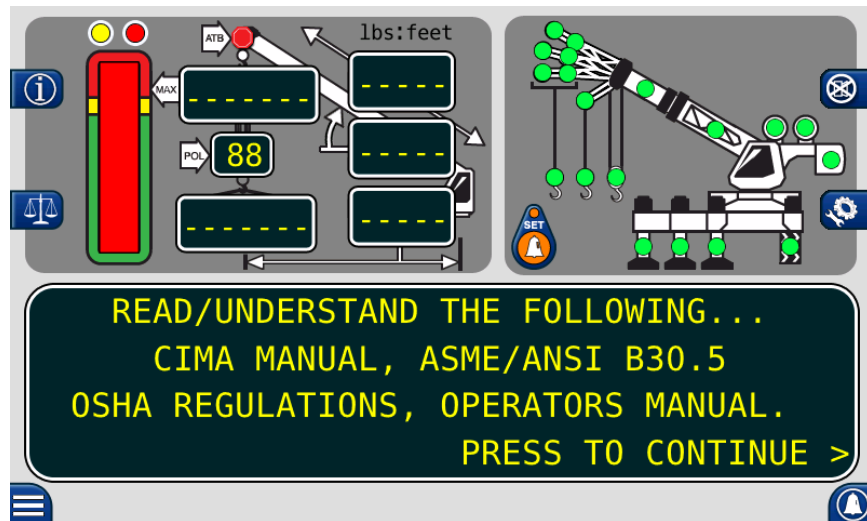

If the above does not occur, see **Display Console Problems**.

11.0 Display Console Problems

Display console problems can be difficult to isolate due to the interaction between the display and the computer unit. Failure of either unit or the cabling connecting the units can cause a malfunction.

To solve problems using the display indicators, observe the display at power up and through the self-test. Diagnose display console problems using the following chart:

Problem	Action
There are no display indications in any of the windows when the power is turned on.	See Internal Status Indicators .
The load, angle, radius, length, and rated capacity windows do not show “188.8” and the bar graph is not fully illuminated during the self-test.	See Replacing the Display Console .
The red and yellow indicators do not illuminate during the self-test.	See Replacing the Display Console .
The display unit does not cycle through the self-test. The data in the display windows appears jumbled with missing segments.	See Replacing the Display Console .
The display lights are illuminated. Load, angle, radius, length, and rated capacity show “188.8” or “888.800” for load and capacity, but the display shows: “Lost communications with main computer”	Display console is OK. Check the connectors on the back of the display console. See The COMM Indicator .

12.0 Fault Reporting and Fault Codes

System fault codes provide ways to locate and assess problems within the Element system. The system performs a brief self-test during power on. Many fault conditions are detected without a system self-test.

Faults detected during the self-test are indicated on the display console:

- The red overload indicator will illuminate.
- The ALARM will sound.
- “WARNING SYSTEM FAULT!” will display at the bottom of the text window.

To view the fault codes, press and hold the **(i)** button as shown.

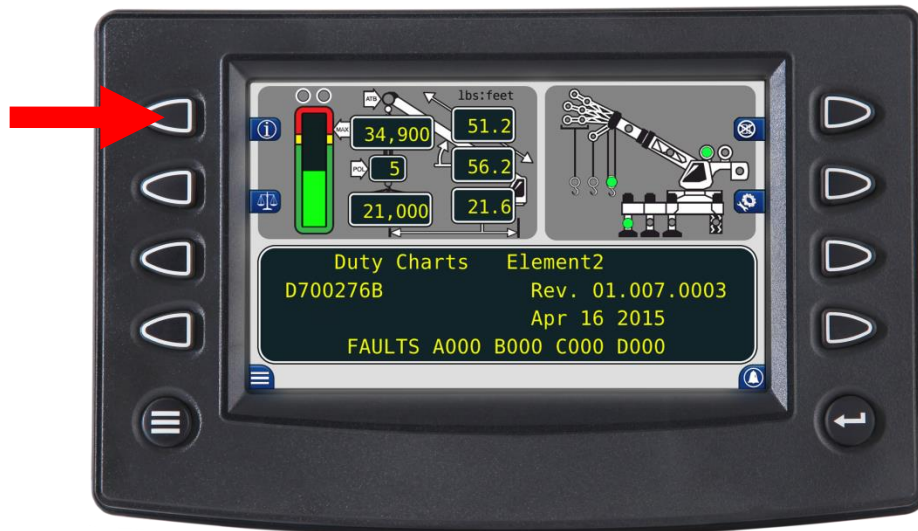

There are four groups of FAULT CODES: A, B, C & D. The function of these groups and a complete listing of each code are provided on the following pages.

NOTE: Always investigate “B” and “C” faults before continuing with “A” and “D” faults.

12.1 Group “A” Fault Codes

Group “A” fault codes represent faults detected for analog sensors.

NOTE: Check and repair “B” and “C” group faults before proceeding with group “A” fault finding sensors.

The following chart details codes in the left column and the actions to take in the right column. If the fault code displayed is not listed, it could be sum of several codes. e.g. Fault Code 3 is sum of Code 1 and Code 2. Fault Code 12 is sum of Code 4 and Code 8.

FAULT CODE	SWING SENSOR	BOOM ANGLE SENSOR	EXTENSION SENSOR	TDX 1 ROD PRESSURE	TDX 0 PISTON PRESSURE	ACTION
000	No Fault Found					None
001					X	See Replacing the Computer (Section 14.3)
002				X		
003				X	X	
004			X			See Calibrating the Extension Sensor Zero (Section 16.3), Calibrating Span of Extension and Angle (Section 16.5)
008		X				See Calibrating the Angle Sensor Zero (Section 16.4), Calibrating Span of Extension and Angle (Section 16.5)
012		X	X			See Calibrating the Angle Sensor Zero (Section 16.4), Calibrating Span of Extension and Angle (Section 16.5)
016	X					See Calibrating the Swing Potentiometer (Section 16.6), & also check swing pot voltage.

12.2 Group “B” Fault Codes

Group “B” fault codes represent faults detected for internal analog functions and power feeds to the function kickout and anti-two block switches.

The following chart details codes in the left column and the actions to take in the right column. If the fault code displayed is not listed, it could be sum of several codes. e.g. Fault Code 3 is sum of Code 1 and Code 2. Fault Code 12 is sum of Code 4 and Code 8.

FAULT CODE	FKO POWER FEED	ATB POWER FEED	DISPLAY CONSOLE	ADC 2 INTERNAL FAULT	ADC 1 INTERNAL FAULT	ACTION
000	No Fault Found					None
008		X				Check ATB wiring for shorts.
016	X					Check the Crane Circuit Breakers

12.3 Group “C” Fault Codes

NOTE: Group “C” fault codes represent faults detected for internal computer memories.

The following chart details codes in the left column and the actions to take in the right column. If the fault code displayed is not listed, it could be sum of several codes. e.g. Fault Code 3 is sum of Code 1 and Code 2. Fault Code 12 is sum of Code 4 and Code 8.

FAULT CODE	SERIAL EEPROM	CRANE DATA	RAM	DUTY DATA	PROGRAM	ACTION
000	No Fault Found					NONE
008		X				Erase crane data.
016	X					See Replacing the Computer (Section 14.3)

12.4 Group “D” Fault Codes

NOTE: Group “D” fault codes represent faults detected for capacity chart selection.

The following chart details codes in the left column and the actions to take in the right column. If the fault code displayed is not listed, it could be sum of several codes. e.g. Fault Code 3 is sum of Code 1 and Code 2. Fault Code 12 is sum of Code 4 and Code 8.

FAULT CODE	WRONG SWING AREA	WRONG BOOM LENGTH	CHART NOT FOUND	ACTION
000	No Fault Found			NONE
001			X	Check other sensor faults first, Ensure the Crane Configuration is correct.
002		X		Boom length is out of range for selected chart. Check crane setup, boom length and extension.
003		X	X	Check other sensor faults first, Ensure the Crane Configuration is correct.
004	X			Swing to correct working area to select chart. Check swing sensor zero position.
005	X		X	Swing to correct working area to select chart. Check swing sensor zero position.
006	X	X		Check other sensor faults first, Ensure the Crane Configuration is correct.
007	X	X	X	Check other sensor faults first, Ensure the Crane Configuration is correct.

13.0 “No Fault Code” Problems

This section addresses problems not reported by the computer fault code system.

13.1 Anti-Two-Block Alarm (ATB)

This section gives direction to fault diagnosis of ATB alarm problems. For detailed information, schematic, and voltages, see **ANTI-TWO-BLOCK FUNCTION OVERVIEW**.

PROBLEM:

- *The Anti-Two-Block alarm is continuously ON. Operating the switch at the boom head does not deactivate the alarm.*

This problem suggests an open circuit between the computer ATB input and the ATB switch, or an open circuit between the computer ATB feed and the ATB switch. Check the reeling drum cable for damage. Ensure the two-block switches are correctly connected. Check the slip-ring and wiring inside the extension reel. Check the signal cable from the extension reel to the computer. Check the connectors.

PROBLEM:

- *The Anti-Two-Block alarm is continuously OFF (safe). Operating the switch at the boom head, by lifting the ATB weight does not activate the alarm.*

This problem suggests a short circuit between the computer ATB input and the computer ATB feed somewhere between the computer and the ATB switch. Check the reeling drum cable for damage. Ensure the two-block switches are correctly connected. Check the slip-ring and wiring inside the extension reel. Check the signal cable from the reel to the computer. Check the connectors.

13.2 Displayed Load or Radius Errors

This section gives direction to fault diagnosis of load and radius errors. Load or radius errors can cause early or late tripping of overload alarms. Accuracy of load is governed by the radius accuracy, and the extension, angle, and pressure sensors. The accuracy of the radius (unloaded) value is governed by the extension and angle sensors.

Ensure there are no system faults before continuing.

13.2.1 Check Boom Extension

1. Ensure the boom is fully retracted.
2. Ensure the reeling drum cable is correctly layered as a single layer across the extension reel surface. Any stacking of the cable will cause extension errors when the boom is fully retracted. This will cause the System to exceed the 0.5 ft. tolerance allowed by the computer for boom mode selection. If the reeling drum cable is stacking on the reel, see **CHECKING THE REELING DRUM CABLE LAYERING**.
3. Check the zero of the extension sensor with the boom fully retracted. Enter the Calibration Mode and use the “SPAN” command. Select sensor No. 2 to view the extension value in feet.

The value of extension must be between -0.2 and +0.2, with the boom fully retracted. If the extension value is incorrect, see **ENTERING THE CALIBRATION MODE**. Fully telescope the boom and ensure the displayed boom length value matches the maximum length of the boom. If the length value is incorrect, follow the **EXTENSION SPAN** procedure in **CALIBRATING SPAN OF EXTENSION AND ANGLE**.

13.2.2 Check Main Boom Radius

NOTE: The required accuracy of taped radius measurements is within 0.1 feet. When taking radius measurements use a good quality tape that does not stretch. The tape should be graduated in feet and tenths of a foot. Always measure between the swing center of the crane and the hook line, using a single part of line with the crane centered over front (rough terrain) or centered over rear (truck crane).

1. Fully retract the boom and ensure the crane configuration is correctly set up.
2. Raise the boom to about 45° and measure the radius. The measured radius must match the displayed radius within +/- 0.1 ft. If it does not match, see **CALIBRATING THE ANGLE SENSOR ZERO** procedure.
3. Raise the boom to a high angle (at least 70°) and measure the angle with the inclinometer. Ensure the displayed angle matches the inclinometer reading within 0.2°. If the displayed angle is incorrect, see the **Angle Span Calibration** procedure in **CALIBRATING SPAN OF EXTENSION AND ANGLE**.

13.2.3 Check Boom Angle

NOTE: The required accuracy of measured angles is within 0.2°. When taking boom angle measurements use a good quality inclinometer. Many inclinometers are only accurate near 0° (level). Ensure the digital inclinometer is securely mounted to the boom.

1. Fully retract the boom.
2. Using an inclinometer set the boom to 0° and ensure the displayed boom angle value is 0.0°. If the angle value is not 0.0°, see **CALIBRATING THE ANGLE SENSOR ZERO**.
3. Raise the boom to a high angle (at least 70°) and measure the angle with the inclinometer. Ensure the displayed angle matches the inclinometer reading within 0.2°. If the displayed angle is incorrect, see **CALIBRATING SPAN OF EXTENSION AND ANGLE**.

13.2.4 Check Pressure Sensors



WARNING! BOTH PRESSURE SENSORS ARE PRE-CALIBRATED FROM THE FACTORY. THE PRESSURE SENSORS CAN NOT BE REPLACED. REMOVAL OR REPLACEMENT OF THE PRESSURE SENSORS FROM THE COMPUTER VOIDS THE WARRANTY AND WILL ADVERSELY AFFECT THE PRESSURE CALIBRATION.

There are two pressure sensors installed as part of the system. Both pressure sensors are mounted within the computer unit. One is connected to the piston side of the boom hoist cylinder via flexible hose; the other is connected to the rod side of the boom hoist cylinder via flexible hose. Both hoses are protected by velocity fuses within the boom hoist cylinder valve block on the end of the cylinder.

The pressure sensor located on the piston side, is subject to the hydraulic pressure needed to support the weight of the boom, any attachments, and the load. The pressure sensor on the rod side monitors the pressure necessary to control the down motion of the boom. The computer unit uses this information (along with other sensors such as extension, length, and angle), to calculate the weight of the suspended load. The maximum continuous working pressure for the sensors is 250 bar (3625 PSI).

NOTE: *The pressure sensing system is calibrated at the factory. Pressure sensors can't be replaced. Any serious problem will necessitate changing the entire computer unit.*

1. Lower the boom until the boom hoist cylinder is fully retracted and on its stop.
2. Loosen the hydraulic connections to the pressure sensors to ensure zero pressure is present on the sensors.
3. Enter the calibration mode and press **Menu Up** button to access **15 PRESSURE MONITOR** to view both sensor pressures and net pressure.
4. Check the pressure values of both sensors. The pressure values should be between -75 and +75 PSI. If not, replace the computer unit.
5. Check the nett pressure value. This should be between -35 and +35 psi. If not, replace the computer unit.

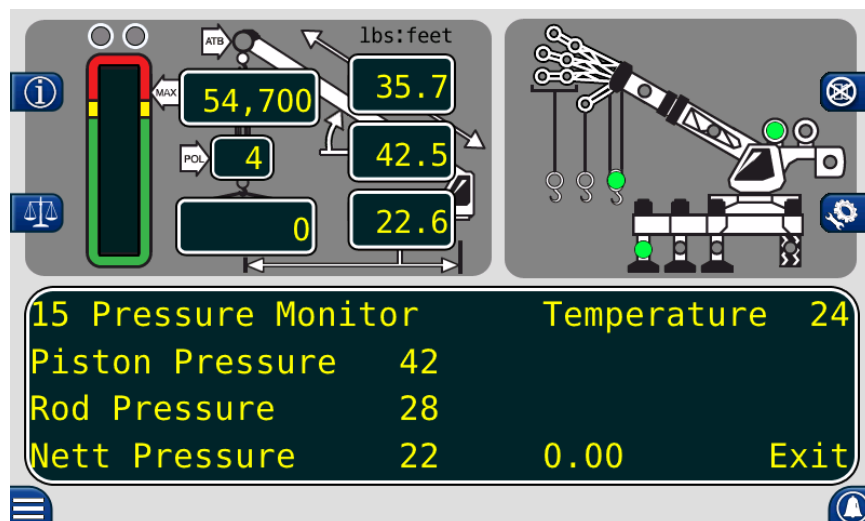

14.0 Computer Unit Overview

The computer unit is the center of the system. It reads the sensors, controls computations and disconnect functions, and communicates with the display console/internal bar graph.

Two hydraulic pressure sensors are contained in the computer unit. These sensors measure the rod-side pressure and piston-side pressure in the boom hoist cylinder. They are factory calibrated at production and cannot be replaced in the field.

NOTE: Due to differences in computer unit configurations, the locations of board components may vary.

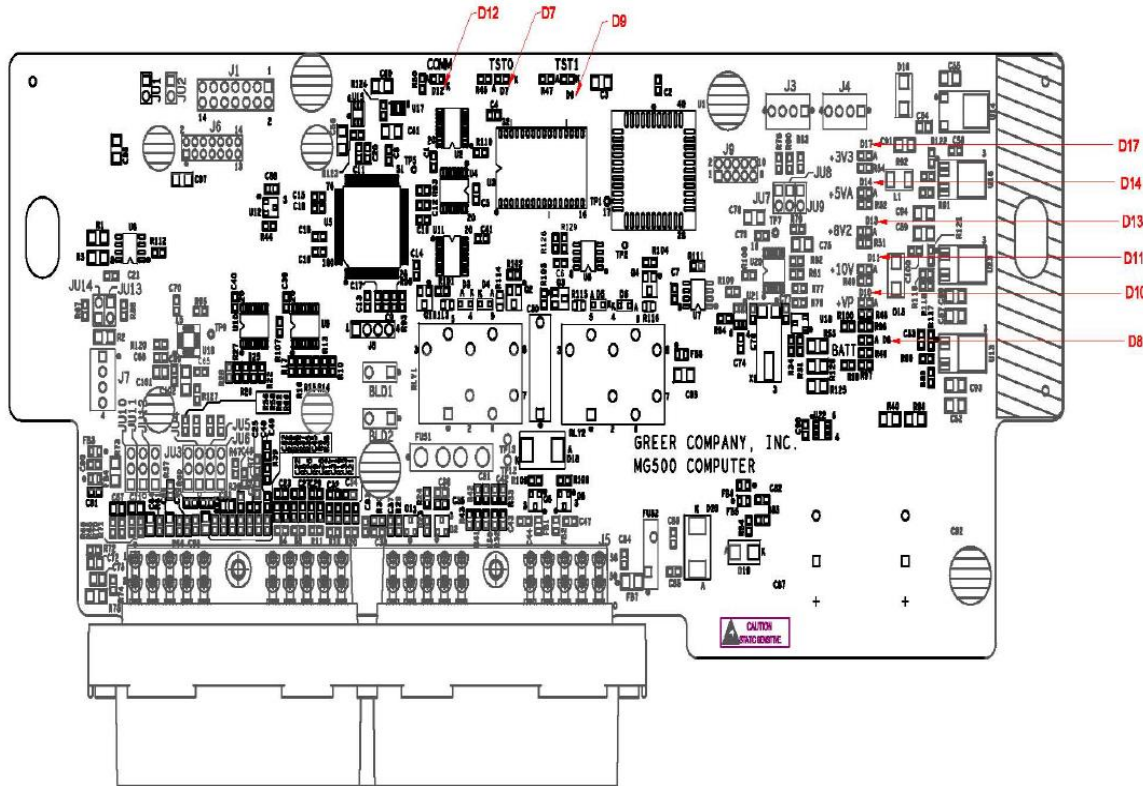

14.1 Internal Status Indicators

The computer unit contains a row of LED indicators for checking computer operation. During normal operation, all LEDs will be illuminated with the COMM indicator blinking. If not, please contact technical support for assistance. Use the following chart and preceding images for LED location.

LED Indicator	Function
D7	Communication Indicator TST0
D8	Battery Power_POS
D9	Communication Indicator TST1
D10	+VP
D11	+10V
D12	COMM (Communication Indicator)
D13	+8V2
D14	+5V
D17	+3V3

14.2 Function Kickout Fuse (FUS1)

NOTE: Prior to replacing the fuse, ensure any electrical shorts have been removed.

The computer unit contains a standard 10 amp replaceable fuse. The fuse protects the function kickout circuit and relay contacts. Replace the fuse if the system error codes indicate that the function kickout power feed is missing. Ensure the crane circuit breaker is closed and power from the crane is present.

14.3 Replacing the Computer Unit

Computer Removal

1. Lower the boom until the boom hoist cylinder is completely retracted and on its stop or the boom is firmly in the boom rest.
2. Disconnect the hydraulic connections at the computer unit. Cap the end of the hydraulic hoses.
3. Disconnect both electrical connectors at the computer unit.
4. Remove the hardware securing the computer to the cab wall.

Computer Installation

1. Secure the computer unit to the cab wall with the mounting hardware.
2. Ensure the electrical connections face downward.
3. Connect the electrical connectors.
4. Remove the protective caps from the hydraulic ports.
5. Connect the base-side pressure, identified with an engraved P, hose to the piston pressure port.
6. Connect the rod-side pressure, identified with an engraved R, hose to the rod pressure port.

15.0 Display Console Overview

The display console allows the user to see the crane values and crane configuration selection. The display also provides calibration functions used for testing and fault diagnosis.

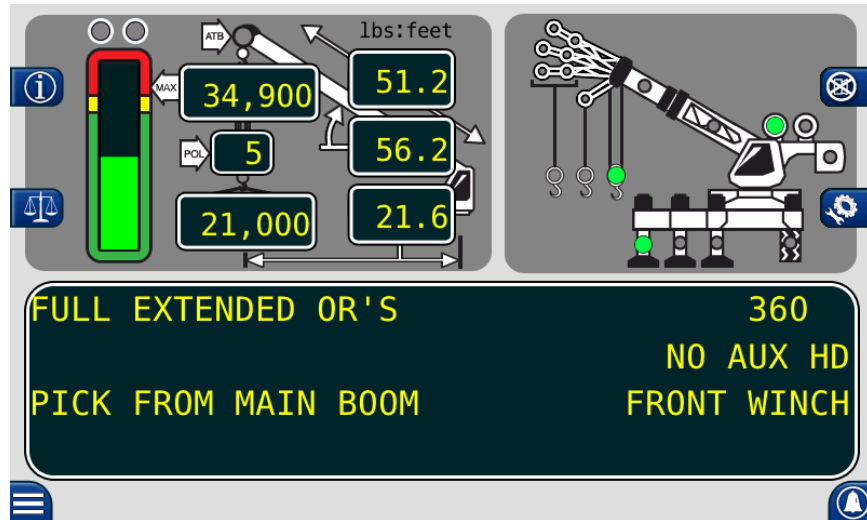

15.1 Checking the Display Console

When operated under extreme conditions the console can become damaged. The damage is not always apparent. To help identify subtle faults that are sometimes difficult to find, please review the following comments.

15.2 Unresponsive Buttons

All button options are not available for use at all times. It is important to verify the non-responsive button:

- Is programmed to respond during the operation of the system. In Calibration Mode, only the circled buttons will work with a few exceptions. The Configuration button will allow you to access the Configuration page, but the user will not be allowed to make any changes.

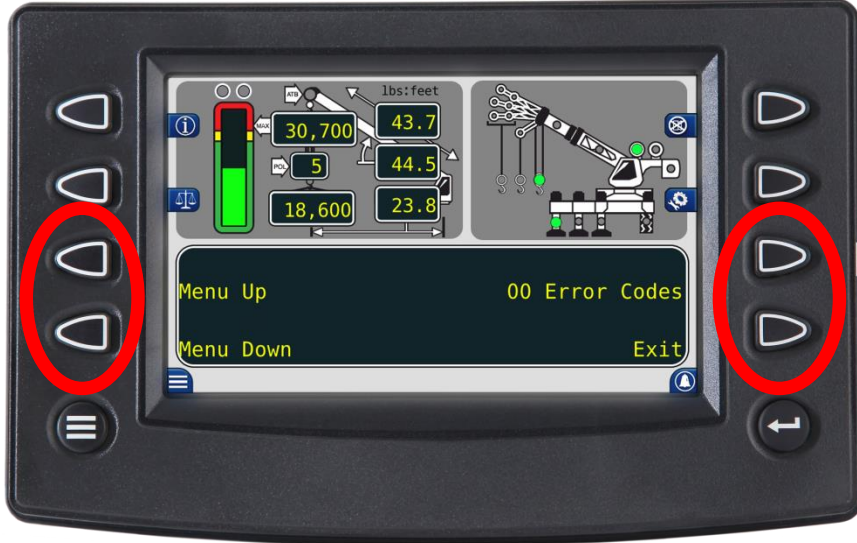

- Being pressed in the center, pressing the printed symbol 'at one end' may not activate the switch underneath.
- Is not damaged or has a surface that is worn which may cause the switch underneath to operate improperly. In this case, see **REPLACING THE DISPLAY CONSOLE**.

15.3 Connectors

Connect the AMP connector in the upper right corner marked 1.



15.4 Horn

Ensure the horn is connected to the wiring harness via the two-pin Deutsch connector.

15.5 Moisture

The display console offers protection against dust and water, when correctly installed.

15.6 Replacing the Display Console

Removal

1. Disconnect the electrical cable from the rear of the operator's display console.
2. Loosen the knob of the ram mount and remove the display.
3. Remove the defective display console from the bracket in the cab.
4. Remove the two screws attaching the ball mount to the display.

Installation

1. Install the ball mount to the display using the two screws.
2. Place the ball mount into the ram mount and tighten the knob to tighten the mount.
3. Connect the electrical cable to the rear of the console.

16.0 Entering the Calibration Mode

The Greer Element system is an aid to crane operation. Do not use this system in place of an operator trained in safety guidelines, crane capacity information, and the crane manufacturer's specifications.

When the computer is new, it has no zero or span calibrations. It is necessary to enter zero and span points for accurate length and angle calculations.

Tools Needed:

- Digital level accurate to 0.1°
- 150-200ft. tape measure graduated in 1/10ths
- Digital multimeter

Pre-Requisites for Calibration

- The crane must be properly set on level ground per the manufacturer's specifications.
- Maximum boom height will be necessary for calibration. Ensure the area is free of overhead obstructions.
- All options such as jibs, fly's, auxiliary heads, etc. must be setup in the computer.

16.1 Calibration Steps

Follow the steps below to ensure proper calibration of the Element unit. Ensure the actual crane setup is reflected on the display. See **Element Operator's Manual** for proper crane configuration after the calibration.

1. To enter **Calibration Mode**, the display must be on the **Home** screen.
2. Press the **Calibration** button to access the **Calibration Security** screen.



3. Enter the security code within 5 seconds, or the system will return to the **Home** screen. Press the buttons in the numerical order displayed.



16.2 Calibration Menus

Once the security code has been entered, the display will show the following menu.

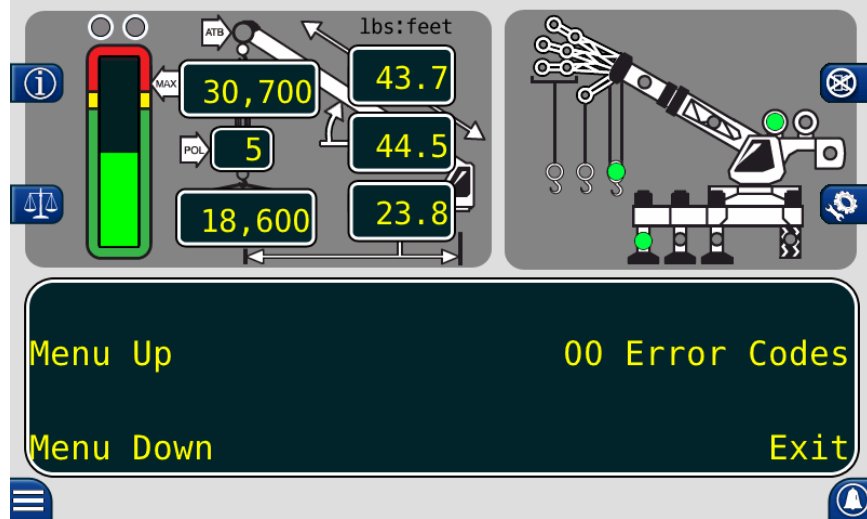

The main menu items used to calibrate the system are:

- 02 Zero Sensors
- 03 Span Sensors
- 04 Swing Potentiometer

The only calibrations needed are for boom extension and boom angle. They must be properly set to zero. On machines with string potentiometer style outrigger position sensors, if a sensor is replaced, it will need to be calibrated. See **CALIBRATING THE OUTRIGGER POSITION SENSOR**.

The system is also equipped with a swing potentiometer. This is designed to track the turret in relation to the chassis.

Boom extension and angle readings are dependent on the correct span values to be entered into the system. These span values are determined by using a digital level on the boom angle, and measuring the span of boom extension.

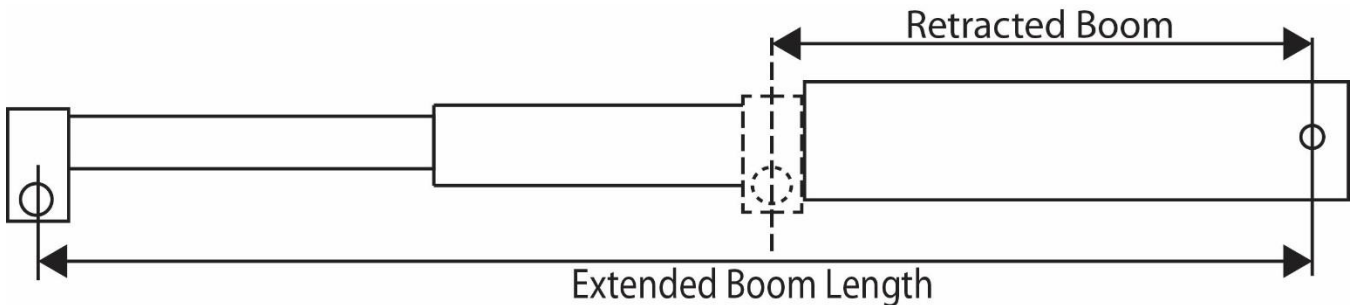

$$\text{Extended Length} - \text{Retracted Length} = \text{Span}$$

16.3 Calibrating the Extension Sensor Zero

1. Fully retract and lower the boom to 0.0°. Verify using a digital level.
2. Remove the cover from the reeling drum to expose the baseplate sensor assembly.
3. Rotate the extension sensor gear clockwise until the clutch drags/clicks, and rotate another ½ turn counterclockwise.
4. The voltage reading between the blue wire TB1-1 and the white wire TB1-3 on the terminal block should measure 0.15V to 0.35V. Rotate the gear to attain the proper voltage with the boom fully retracted.

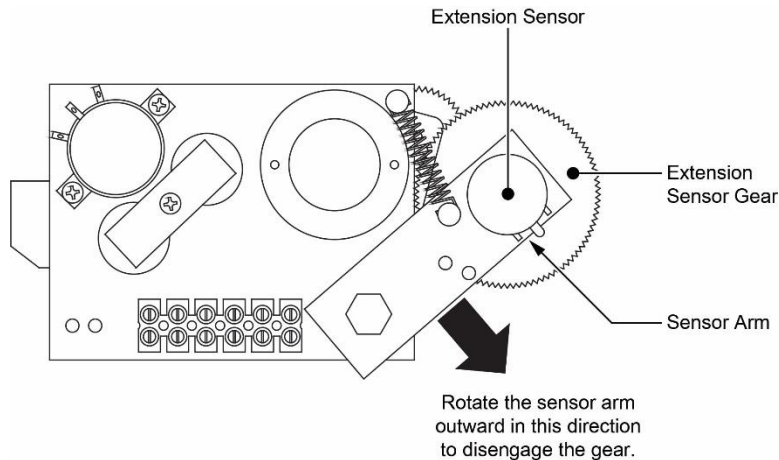

5. Press the **Menu Up** button until **02 Zero Sensors** is reached.
6. Press the **02 Zero Sensors** button.
7. Press the **Zero No. 2 =** button to be prompted with **Yes! Calibrate!**
8. Press the button a second time to calibrate the zero.
9. The display will then read **Zero No. 2 = 0** as shown. The retracted boom length will be displayed in the boom length window. Extension zero calibration is complete.

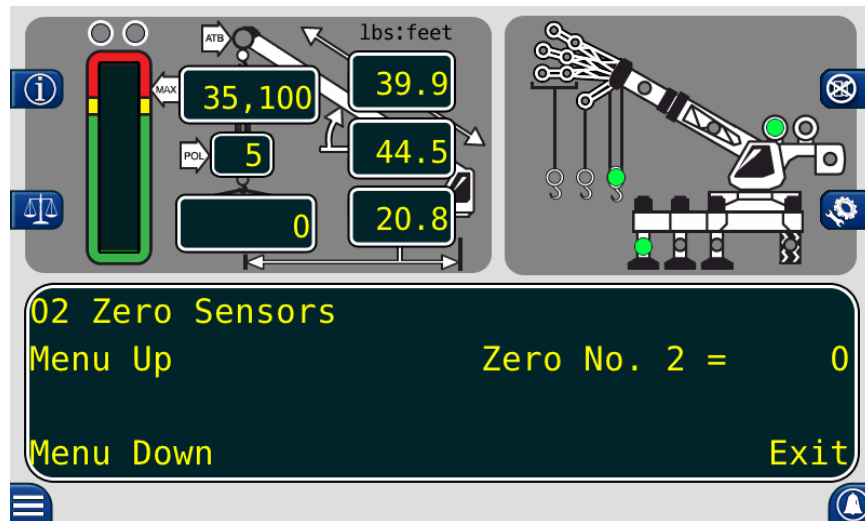

16.4 Calibrating the Angle Sensor Zero

The angle sensors are preset to zero on the potentiometer before leaving the factory. If the potentiometer is disturbed, the zero setting can be affected. If this happens, the angle sensor will be inaccurate.

If the factory setting has been disturbed, reestablish it by loosening the securing screws, and rotating the pot until the desired voltage reading is attained.

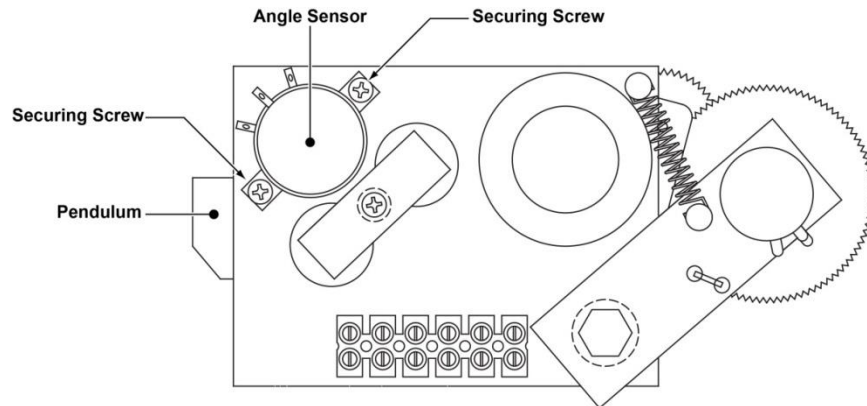

1. Place the boom to 0.0 degrees. Verify using a digital level.
2. Check the voltage between TB1-1 and TB1-2. It should measure between 0.4V and 0.6V in the correct position.
3. Enter the **02 Zero Sensors** menu. Press the **Menu Up** button to display **Zero No.3 = 0**. The calibration and boom angle window should read 0.0.
4. Press the **Zero No. 3 =** button to be prompted with **Yes! Calibrate!** Press the button a second time to calibrate the zero. The calibrating the angle sensor zero routine is complete.

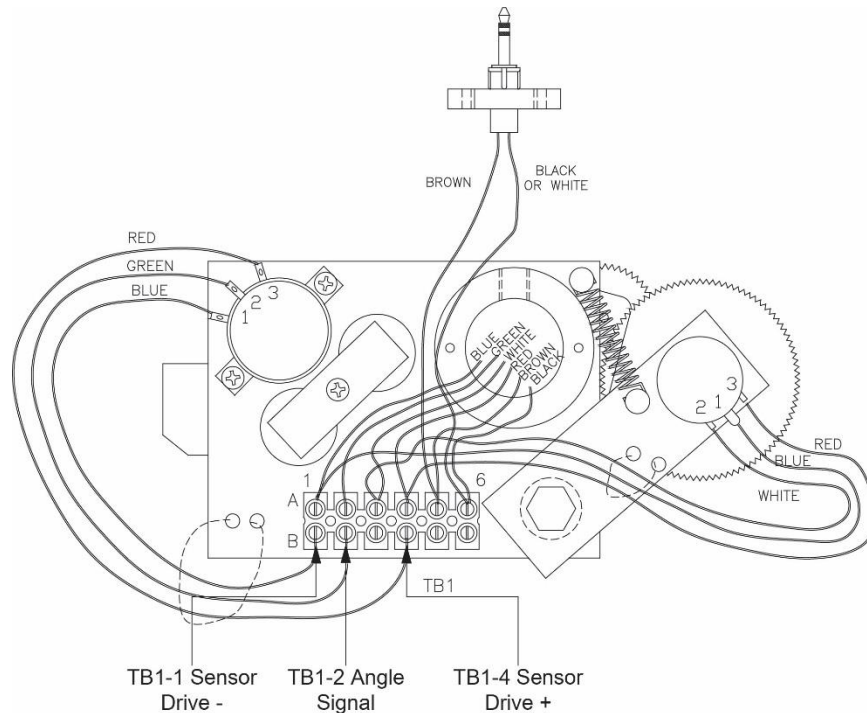

16.5 Calibrating Span of Extension and Angle



WARNING! THE AREA OVERHEAD ABOVE THE CRANE MUST BE CLEAR OF OBSTRUCTIONS PRIOR TO CALIBRATING SPAN OF EXTENSION AND ANGLE!

In order for the system to properly calculate the boom length and the boom angle, the “Span Number” must be entered into the system. Obtain the Span Number with the following steps:

1. Measure the boom from the base foot pin to the center of the head sheave pin. Record this measurement.

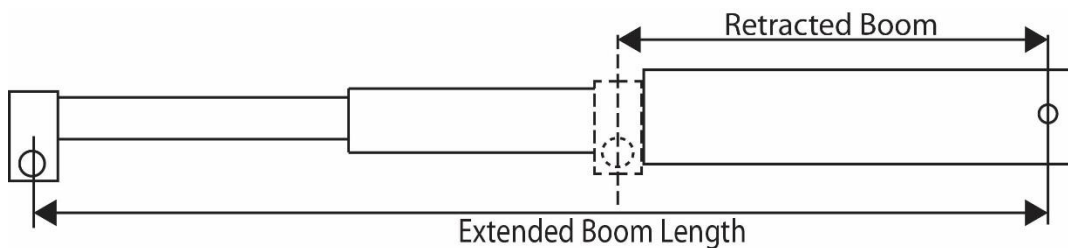

Extended Length – Retracted Length = Span

2. Raise the boom to between 60-65° and fully extend the boom. Record the measurement from the digital level for entry into the system later in this procedure.
3. From the calibration menu screen, press the **Menu Up** button until **03 Span Sensors** and press the button.
4. Press the **Span No. 2 = X.X** button.
5. Press the button again to be prompted with **Yes! Calibrate!**
6. Press the **Yes! Calibrate!** button.
7. Use this screen to enter the span (Extended Length – Retracted Length = Span).

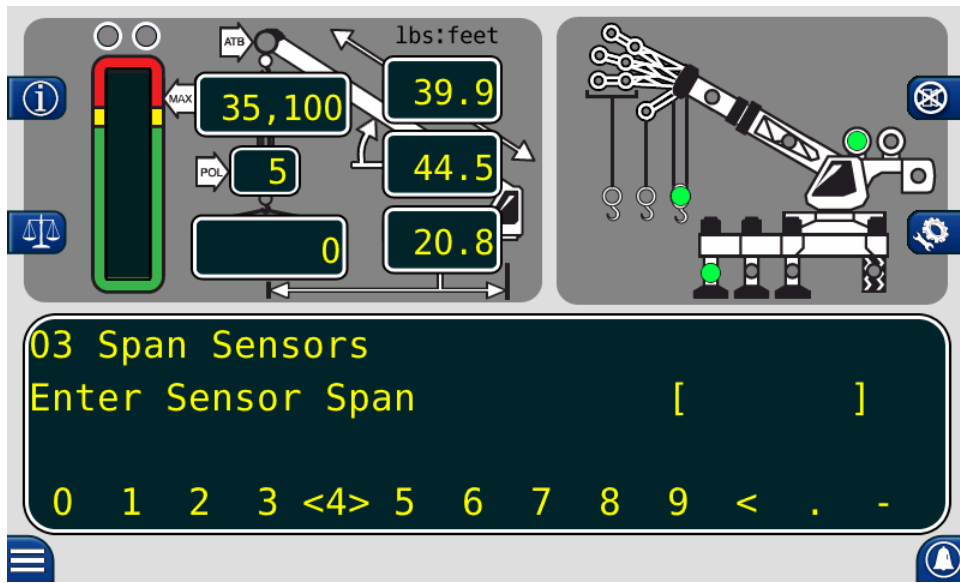

8. The lower left and lower right buttons are used to select the number. The number inside the brackets is the current selection, in this image, the number 4 is between the brackets.

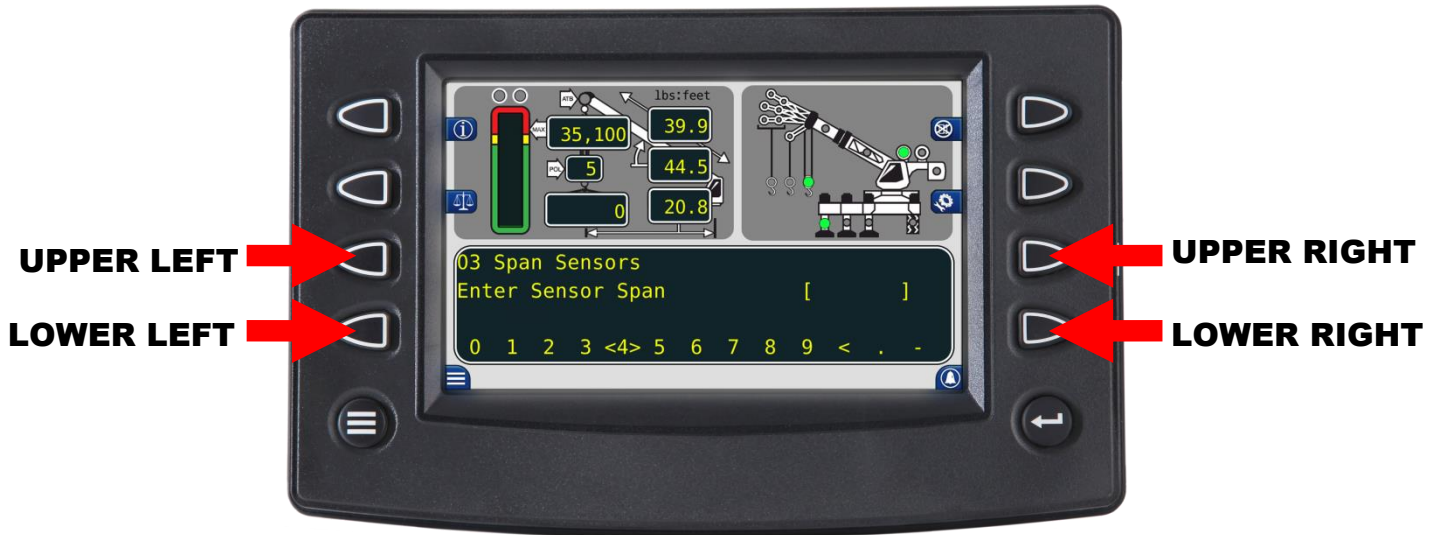

9. Use the upper left button to enter the numbers one at a time.
10. When the number is entered, press the upper right button to enter the number into the system memory. Span of extension is now complete.
11. Press the **Menu Down** button to display **Span No. 3 = xx.xx**.
12. Press the **Span No. 3 = xx.xx** button.
13. Press the **Yes! Calibrate!** button.

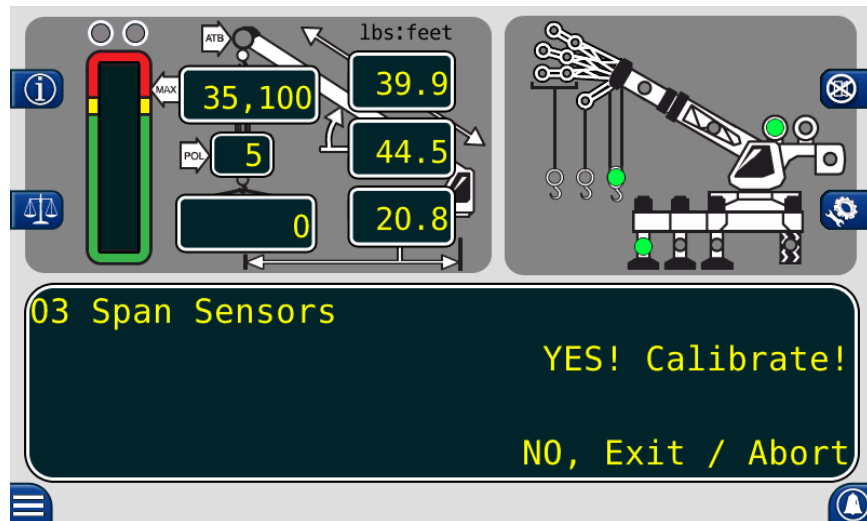

14. You will be prompted with the same screen from step 6. Use this screen to enter the span of angle measurement from the digital level.
15. This calibration routine is now complete. Press the **Exit** button to return to the calibration menu.

16.6 Calibrating the Swing Potentiometer

After completing the extension and angle span, return to the main calibration screen.

1. Press the **Menu Up** button until **04 Swing Potentiometer** is reached. This menu will allow a zero point to be set on the swing circle and a direction for the system to track the rotation angle.
2. The swing must be in the stowed position and the house lock engaged.

NOTE: Inaccuracy in the swing zero setting may result in the loss of load chart for pick and carry.

3. Press the **Zero** button to zero the swing.

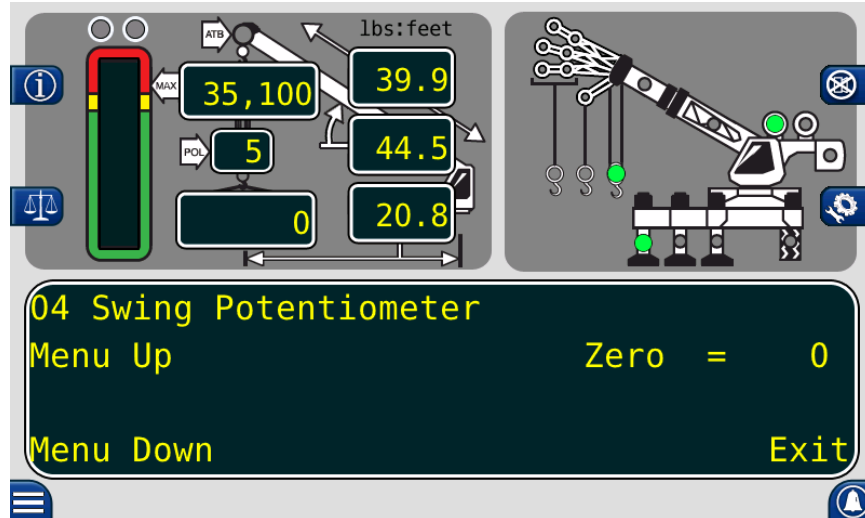

4. The swing potentiometer zero is now set.

16.6.1 Calibrating Swing Direction

For consistency, the swing should count upwards (0, 1, 2, 3, etc.) when rotating clockwise. The direction of the swing can be changed while using the Greer Element display.

1. With the zero calibrated, if the swing direction is wrong, press the **Menu Up** button twice.
2. Press the **Direction = '-'** button to reverse the direction.



16.6.2 Cranes with Swing Switches

On units with swing switches, the swing potentiometer input can be disabled.

1. Enter the calibration mode and press the **Menu Up** button to **04 Swing Potentiometer**.
2. Press the **04 Swing Potentiometer** button and press the **Menu Up** button until the **Remove Swingpot?** option is displayed.

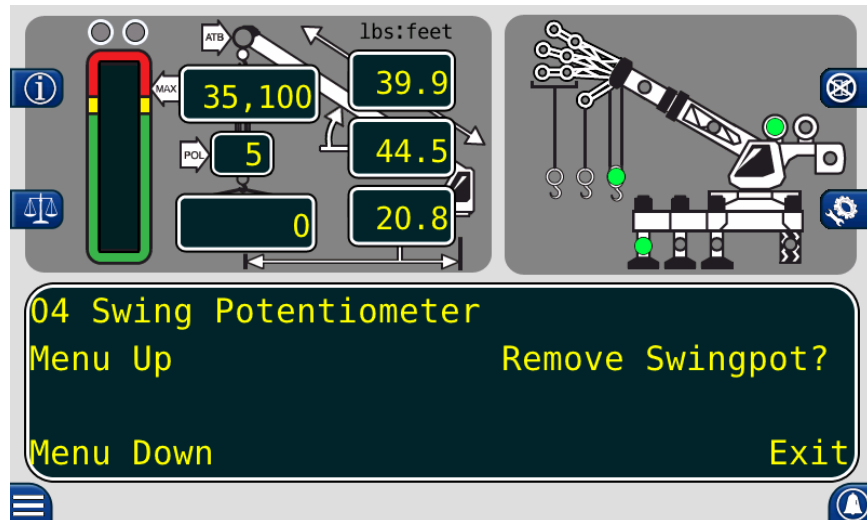

3. Press the **Remove Swingpot?** button.
4. The crane will now use the swing switches.

16.7 Calibrating the Outrigger Position Sensors

If an error code is displayed for a particular outrigger sensor, contact service for assistance.

For cranes with digital switch outrigger position sensors, contact service for assistance. No calibration is needed.

When directed by service to replace the string potentiometer outrigger position sensors, calibration is needed.

1. Enter the **Outrigger Sensor** calibration menu.
2. In the lower left portion of the screen, **Current Sensor: = CAN String Pots** will be displayed. If this is not correct, press the button once to toggle to **Current Sensor: = CAN String Pots**.

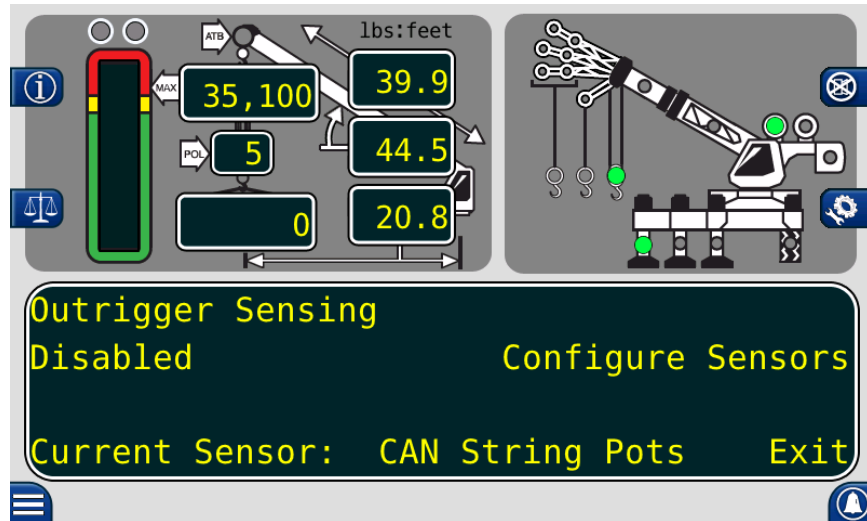

3. Press the **Configure Sensors** button.
4. Install the outrigger position sensors one at a time.
 - a. Install the front left string potentiometer. **New Device Found** will appear on the display.

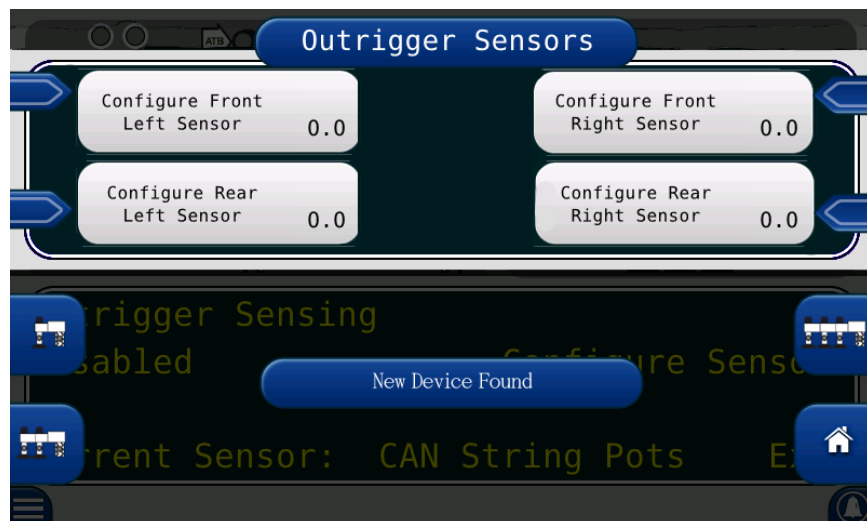

- b. Press the **Configure Front Left** button to identify the new sensor location in the computer.

- c. Repeat these steps and install the remaining sensors.
 - d. The message will change from **Configure** to **Reset** when calibration is finished.
5. With all sensors installed, ensure the outriggers are in the fully retracted position. Press the **Fully Retracted Position** button to set the retracted position in the computer.

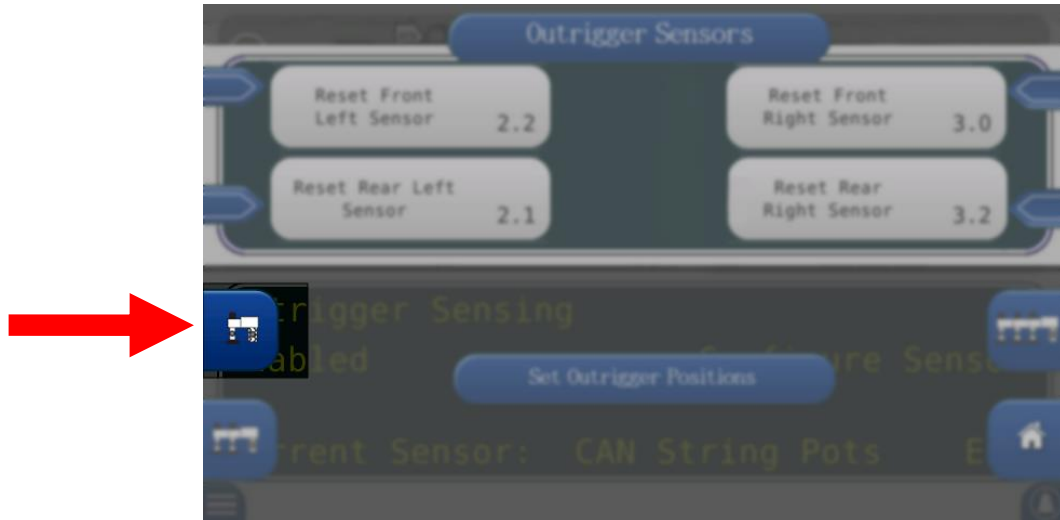

6. Move the outriggers to intermediate position and press the corresponding button to set the intermediate outrigger position.

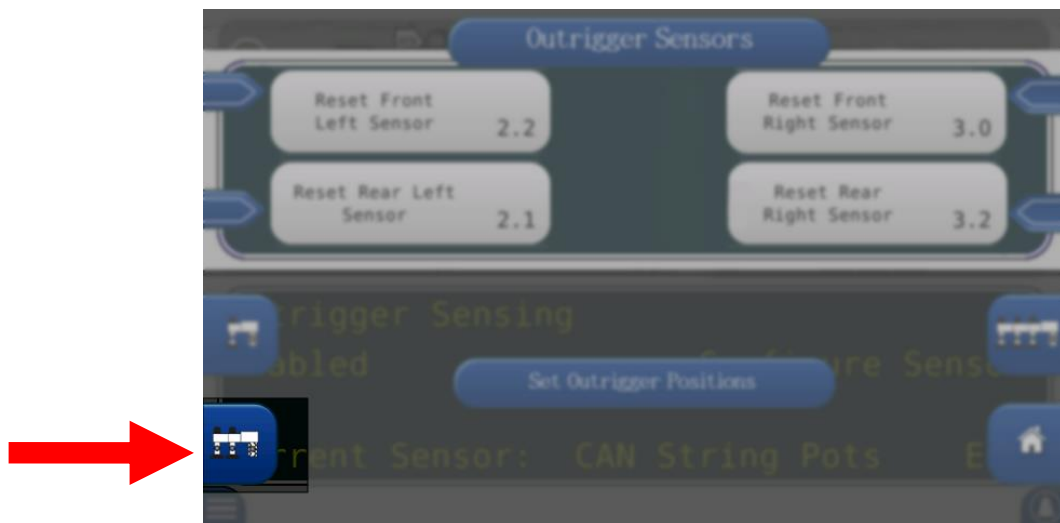

7. Move the outriggers to fully extended position and press the corresponding button to set the fully extended outrigger position.



8. The outrigger position sensors are now calibrated.

16.7.1 Enabling and Disabling the Outrigger Position Sensors

In the **Outrigger Sensing** menu, the user can Enable or Disable the Outrigger Position Sensors. Press the indicated button to toggle between the two options.



16.8 Calibrating the Frame-Level Sensor (If Equipped)

This is the procedure for calibrating the Frame-Level sensor on a new machine, or after replacing a faulty Frame-Level sensor. Ensure the sensor is mounted to a flat surface, this can affect the calibration.

1. Press the **Menu** button.
2. Press the **Frame-Level Sensor** button.



3. This will access the Frame-Level screen.

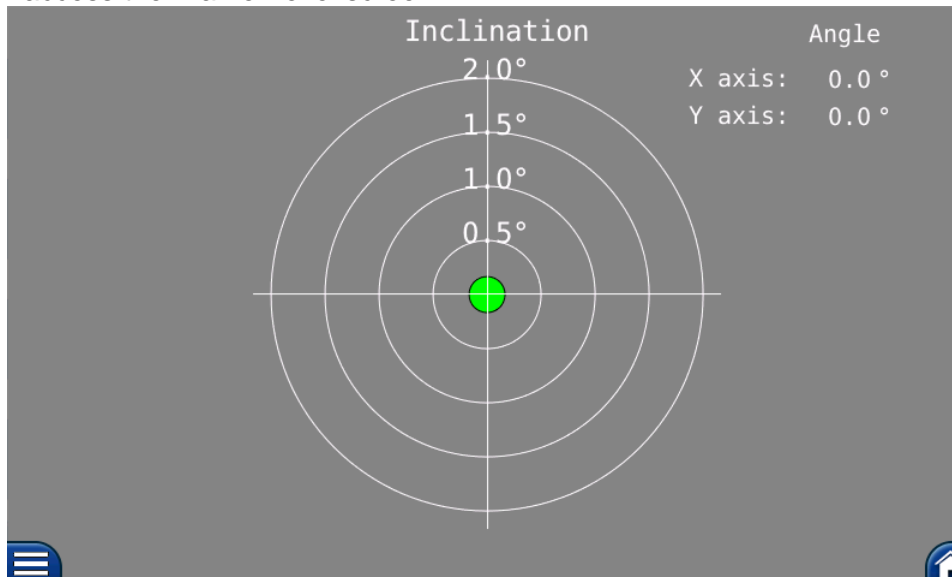

4. Enter the security code to calibrate the Frame-Level sensor. Press the buttons in the order shown.



5. This allows access to the **Configure Sensor** and **Zero Sensor** buttons.



6. Press the **Configure Sensor** button to activate the sensor.

NOTE: To ensure proper operation, this must be done the first time the device is connected and powered on. This must also be performed with a replacement sensor, in the event of a failure.

7. Using a method other than the Frame-Level sensor, ensure the machine is level on the X-axis and the Y-axis.
8. Press the **Zero** button. The display will now show 0.0° for the X and Y-axis.

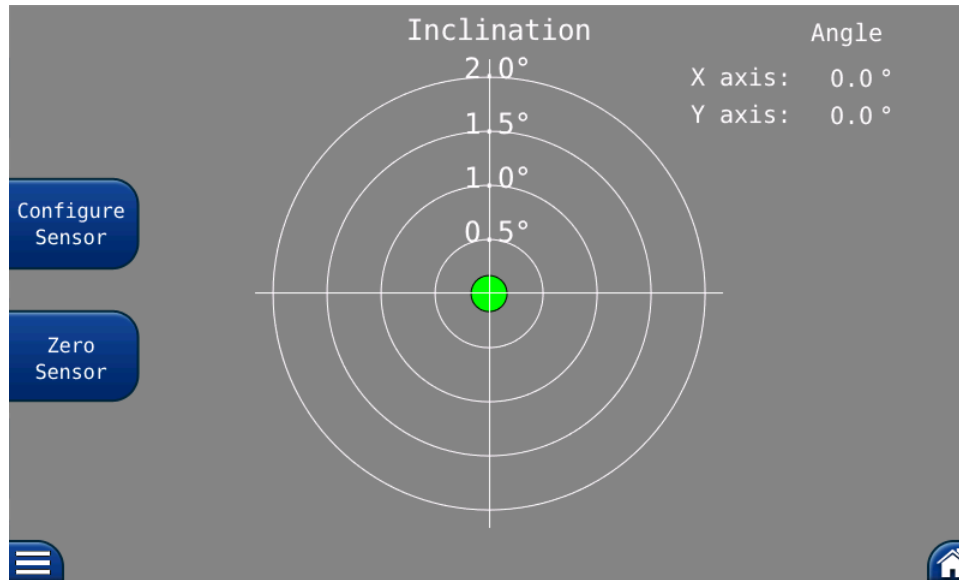

9. The Frame-Level sensor is now calibrated.

16.9 After the Calibration Routine

When the calibration routine is complete, thoroughly test the machine to ensure the radius is accurate to + 0.5 of a foot.

In order to perform load testing, a known weight is necessary. Perform testing from 2-3 different boom angles, as well as extensions.

The load shown must be within 0 to +10% when testing. If the load is outside these limits, the calibration should be rechecked for accuracy. The displayed load should not be lower than the actual weight.

17.0 Reeling Drum Overview

The primary operation of the reeling drum is to measure the extension of the telescoping sections of the main boom. The reeling drum also includes an angle sensor to measure the main boom angle along with an electrical slip-ring which transfers the two-block signal from the reeling drum cable to the system computer. It is important the setup and maintenance of these devices is properly carried out per the procedures in this manual. Incorrect maintenance can result in system calculation errors.

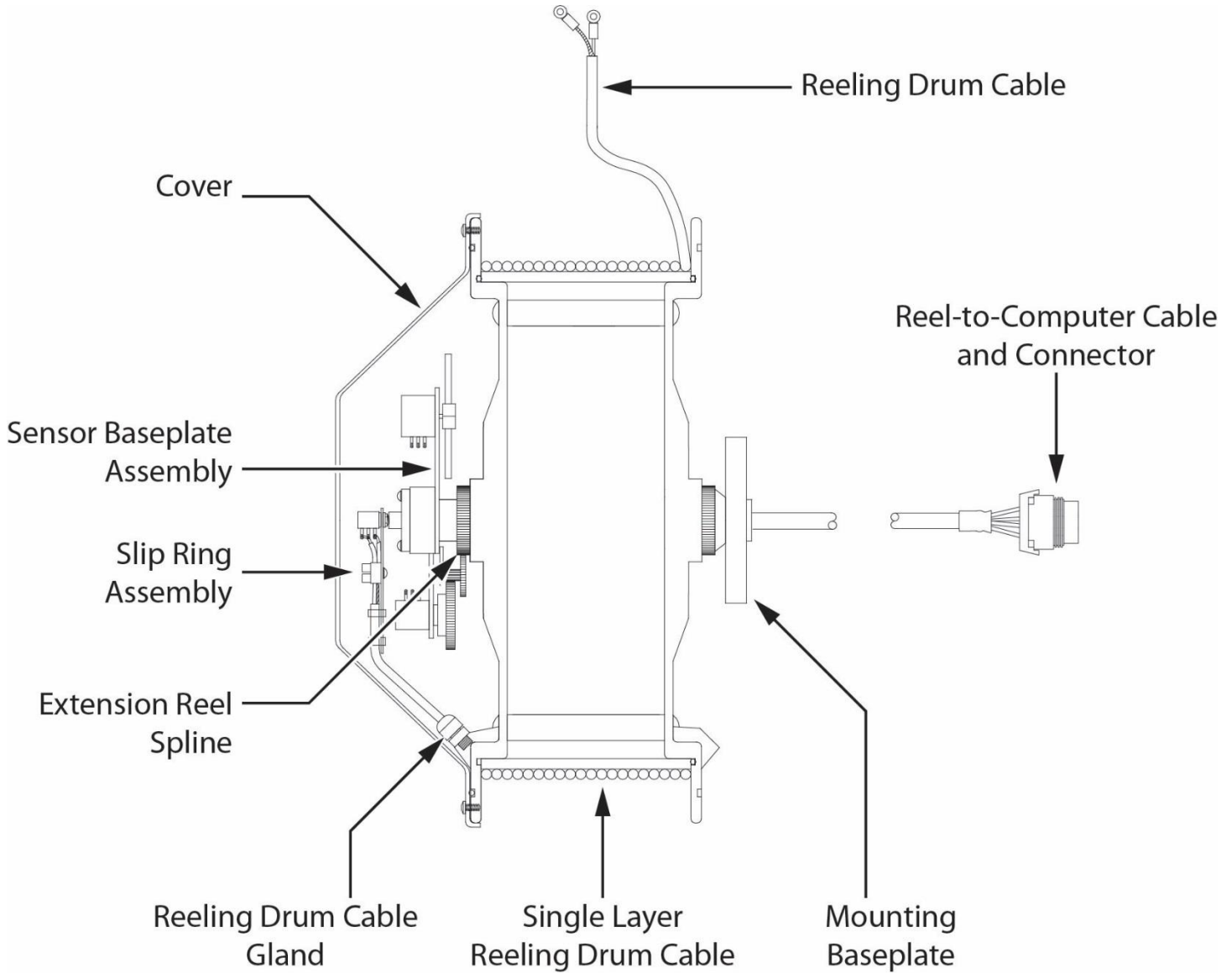

17.1 Checking the Reeling Drum Cable Layering

The reeling drum is designed to provide accurate measurement of boom extension. To provide accurate measurement, the reeling drum cable must form a single flat layer across the surface of the reeling drum as the boom is telescoped in and out. Any stacking of the cable will cause extension errors as the boom retracts.

1. Telescope the boom fully out and then fully in.
2. Ensure the reeling drum cable forms a flat single layer across the surface of the extension reel, with each successive turn of cable lying next to the last.

NOTE: If any stacking or build up of the cable occurs, ensure the first cable guide at the top of the boom root section is correctly aligned with the outside edge of the extension reel. Clean the reeling drum cable and lubricate it with a silicone spray.

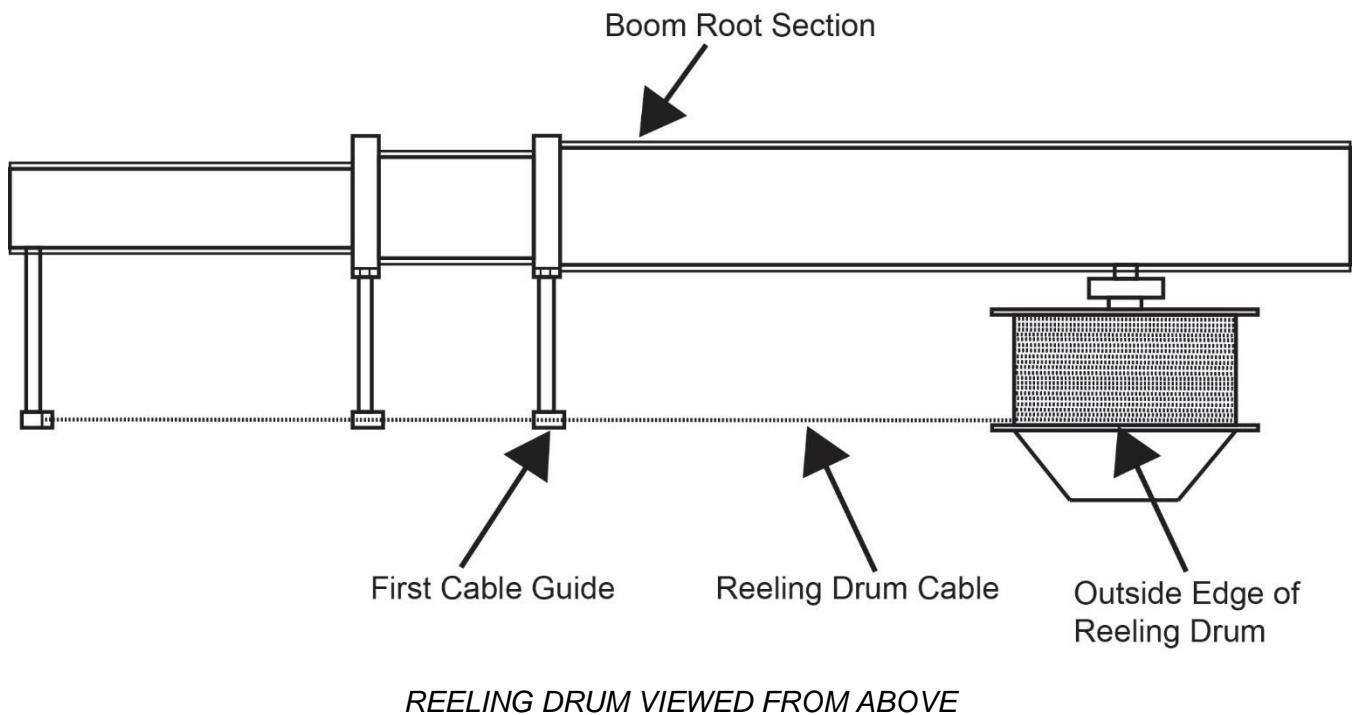

17.2 Sensor Baseplate Assembly

The sensor baseplate assembly supports and connects the extension and angles sensors. It also supports the Anti-Two-Block switch signal and signal cable to the computer.

Electrical or mechanical failure of either the angle sensor or the extension sensor potentiometers cannot be repaired in the field. The angle sensor pendulum is factory set on the potentiometer shaft and the extension potentiometer gear contains a protection clutch which is difficult to replace in the field.

In the event of failure of either item, replace the entire sensor baseplate assembly.

The terminal block (TB1) mounted on the assembly provides wiring connection for all internal parts of the reeling drum and the reel-to-computer cable. Most electrical diagnoses of the boom sensors can be made at this terminal block.

If problems occur with the two-block alarm operation, angle, or extension sensor, refer to the following chart. Follow the Boom Position/Action column before performing any voltage checks. Measure all voltages with a digital voltmeter set to DC volts range.

SIGNAL	BOOM POSITION/ ACTION	VOLTAGE		VOLTMETER CONNECTION	
		MIN	MAX	RED (+)	BLACK (-)
SENSOR DRIVE	-	+4.7V	+5.3V	TB1/4 - RED	TB1/1 - BLUE
ANGLE SENSOR OUTPUT	0 degrees	0.4V	0.6V	TB1/2 - GREEN	TB1/1 - BLUE
EXTENSION SENSOR OUTPUT	0 ft. FULL RETRACTED	0.15V	0.35V	TB1/3 - WHITE	TB1/1 - BLUE
TWO-BLOCK DRIVE	A2B WEIGHT DOWN	5.5V	7.5V	TB1/6 - BLACK	TB1/1 - BLUE
	A2B WEIGHT UP	9.5V	10.5V	TB1/6 - BLACK	TB1/1 - BLUE
TWO-BLOCK SIGNAL	A2B WEIGHT DOWN	5.5V	7.5V	TB1/5 - BROWN	TB1/1 BLUE
	A2B WEIGHT UP	0V	2V	TB1/5 - BROWN	TB1/1 - BLUE

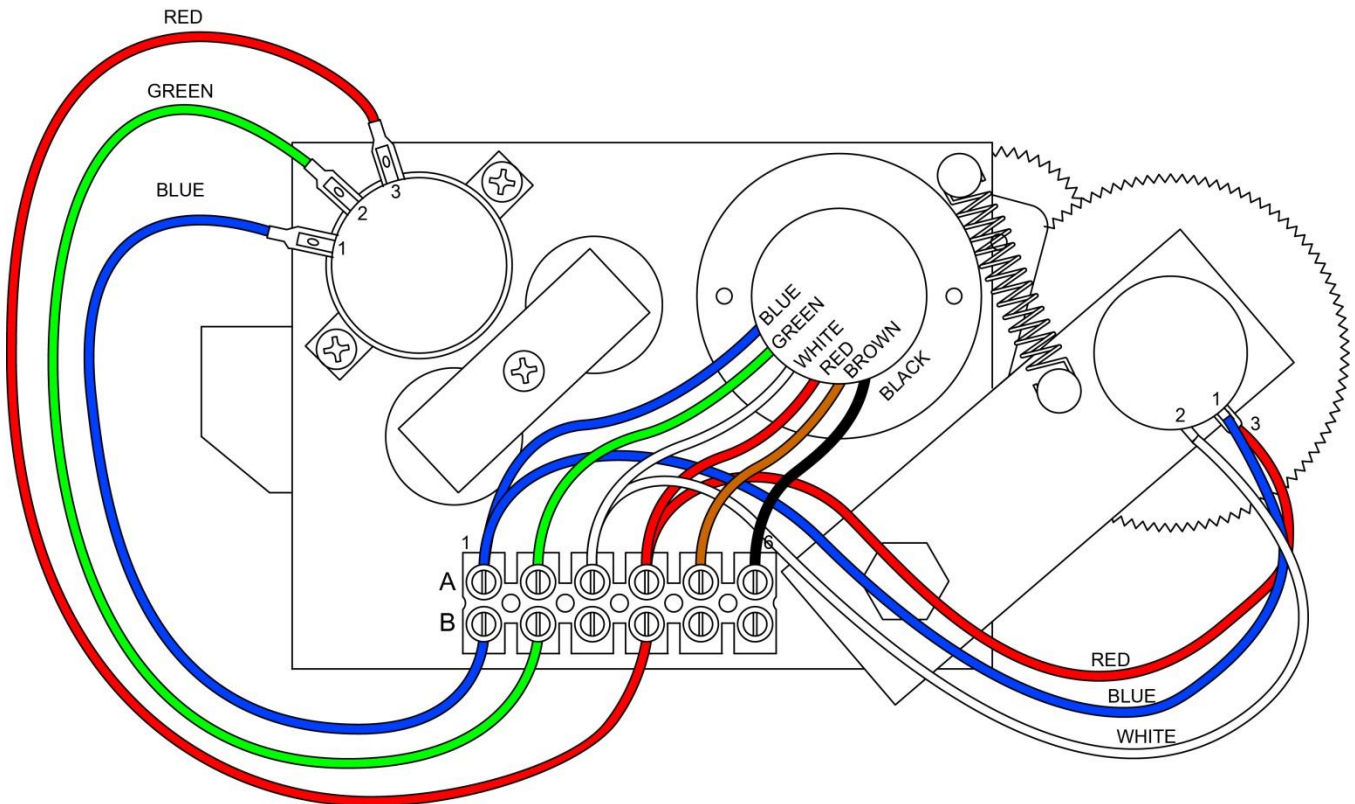

17.3 Anti-Two-Block Function Overview

The computer supplies a protected positive feed to the Anti-Two-Block switches at the boom/jib head via the reel-to-computer cable, slip-ring, and reeling drum cable. With the Anti-Two-Block weight hanging freely on the switch, the switch contact is closed and the signal return to the computer is high. When the weight is lifted by the hook block, the switch contact is opened and the computer will sense a low signal input from the ATB signal return.

Since the computer checks the protected feed voltage internally, the system is capable of detecting a short circuit of the feed (or the ATB signal return when the switch is closed) to the crane chassis. Fault codes are defined in **FAULT REPORTING AND FAULT CODES**.

Most problems with the ATB circuit may be identified through inspection of cables, switches, and the reeling drum. Damage to these parts may result in continuous or intermittent ATB alarms.

17.4 Checking the Reeling Drum Cable

The outer braid of the cable carries the Anti-Two-Block feed to the switches. If the cable sheath is damaged, it may cause a short circuit to the boom/chassis and indicate the fault code above “B008.” See **GROUP “B” FAULT CODES**. The same fault code will be indicated if the ATB switch is closed and the inner core of the cable is shorted to the chassis at some point in the wiring.

1. Carefully inspect the reeling drum cable for wear.
2. Check for signs of damage to the outer sheath of the cable.
3. Check for any signs of severe “kinking” or crushing of the cable.

17.5 Checking the Anti-Two-Block Circuit

This procedure checks the ATB circuit when no power is applied to the circuit, use the diagram on the following page. Before continuing, ensure the connectors are correctly connected to the ATB switches at the boom head/jib.

1. Remove the reeling drum cover.
2. Disconnect the slip-ring arm from the plug by pulling it away from the center of the reel.
3. Close the ATB switch at the boom head by suspending the weight from it or pulling on the chain.
4. Measure the resistance on TB2, between A2 & B2 terminal connections on the sensor arm.
5. With the ATB switch closed, the resistance should be less than 300 ohms. If not, inspect the reeling drum cable, ATB switch, and the boom head connectors for an open circuit.
6. Open the ATB switch at the boom head by lifting the weight.
7. Measure the resistance on TB2, between A2 & B2 terminal connections on the sensor arm.
8. With the ATB switch open, the resistance should be greater than 10,000 ohms. If not, inspect the reeling drum cable, ATB switch, and the boom head connectors for a short circuit.

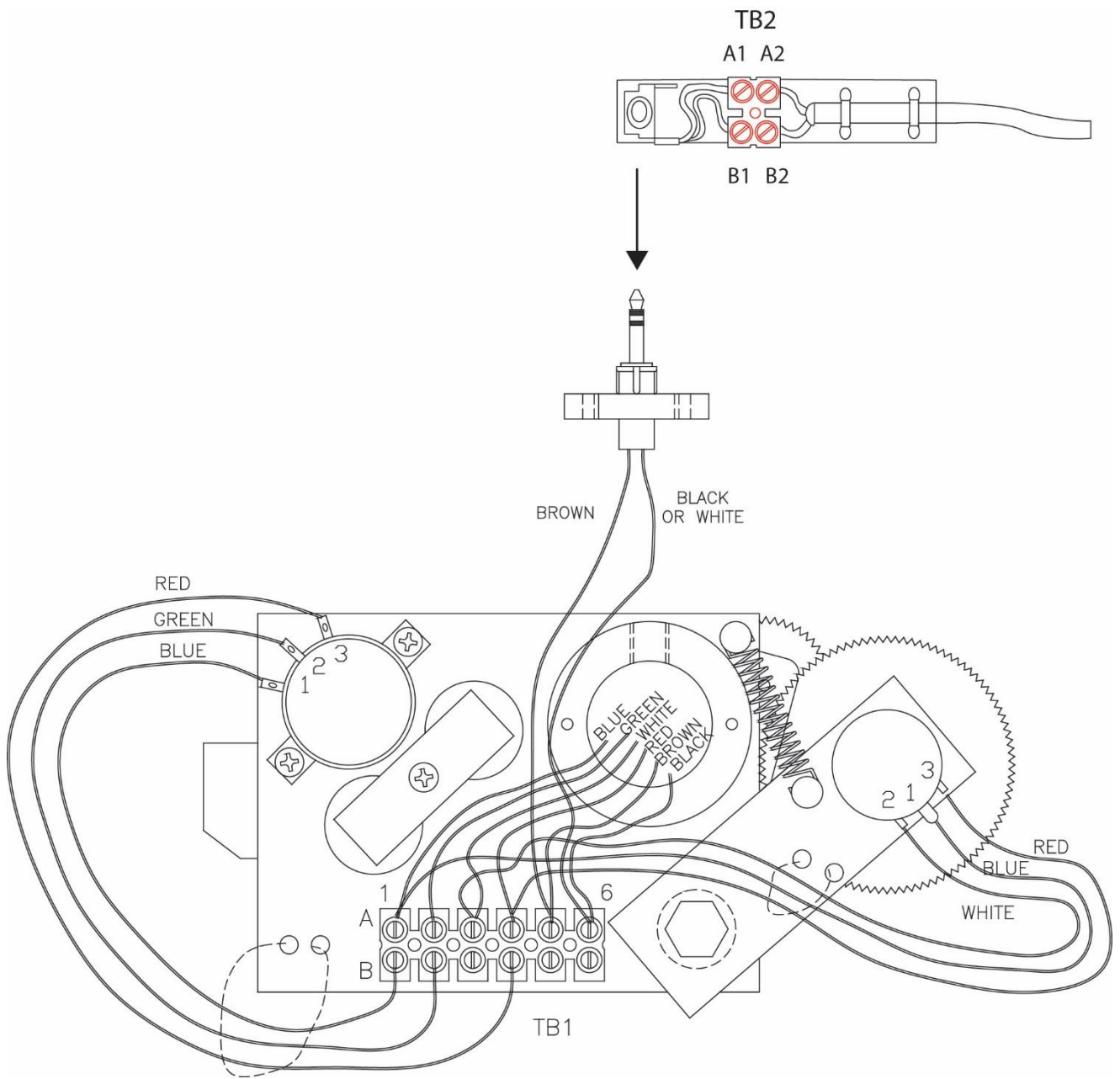

18.0 Swing Sensor Overview

The swing sensor measures the angle of the upper structure of the crane relative to its carrier. This angle is used to select capacity charts and operator swing alarms/working area alarms. If the swing sensor fails, the computer will be unable to select a valid capacity chart.

For fault diagnosis, access the swing sensor by removing the collector cover at the cranes swing center. Refer to the figure below.

For swing sensor replacement procedures, consult crane manufacturer.

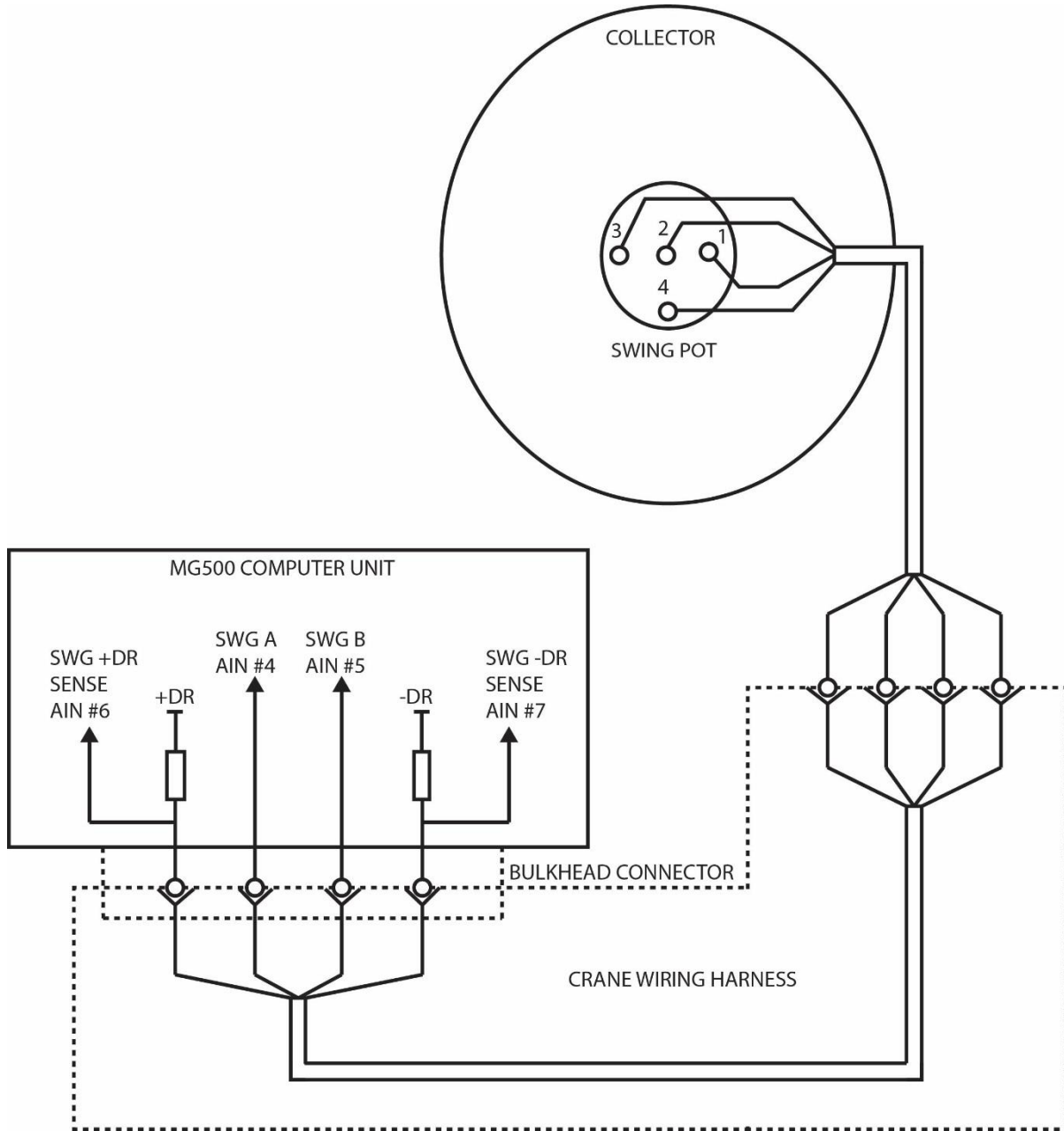

18.1 Checking the Swing Sensor Drive Voltage

1. Remove the collector ring cover to expose the swing sensor.
2. With the system power turned on, measure the voltage between Terminal 1 of the swing sensor and crane ground. The voltage should be between 4.4 and 4.8 volts.
3. Measure the voltage between Terminal 3 of the swing sensor and crane ground. The voltage should be between 0.2 and 0.5 volts.

NOTE: Voltages outside of those shown in steps 2 and 3 indicate a problem with the swing sensor or cabling connections. If voltages are incorrect, see **CHECKING THE SWING SENSOR RESISTANCE**.

18.2 Checking the Swing Sensor Output Voltage

1. Remove the collector ring cover to expose the swing sensor.
2. With the system power turned on, measure the voltage between Terminal 2 of the swing sensor and crane ground. The voltage should be between 0.2 and 4.8 volts.
3. Measure the voltage between Terminal 4 of the swing sensor and crane ground. The voltage should be between 0.2 and 4.8 volts.

NOTE: Voltages outside of those shown in Steps 2 and 3 indicate a problem with the swing sensor or cabling connections. If voltages are incorrect, see **CHECKING THE SWING SENSOR RESISTANCE**.

18.3 Checking the Swing Sensor Resistance

1. Disconnect the connector located behind the collector ring.
2. Measure the resistance between pins C and D of the connector on the swing sensor side. The resistance should be between 2200 and 2800 ohms.
3. Measure the resistance between pins A and B of the connector on the swing sensor side. The resistance should be between 1800 and 2300 ohms.

NOTE: Resistances outside of those shown in steps 2 and 3 indicate a problem with the swing sensor or associated cable connections. If resistances are incorrect, replace the swing sensor and its cable.

19.0 Frame-Level Sensor (If Equipped)

The Frame-Level sensor measures the angle of the chassis relative to 0.0°. It is important to have the machine level before performing a lift.

If the Frame-Level sensor fails, the indicator on the screen will turn red and no measurement will be available.

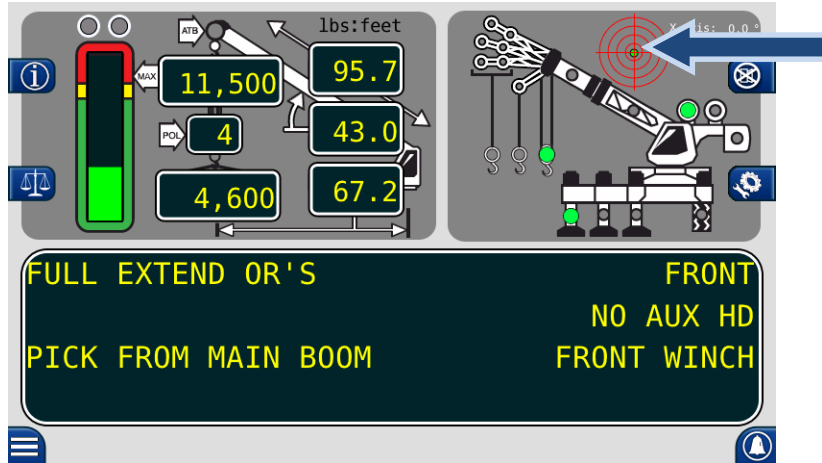

Home Screen

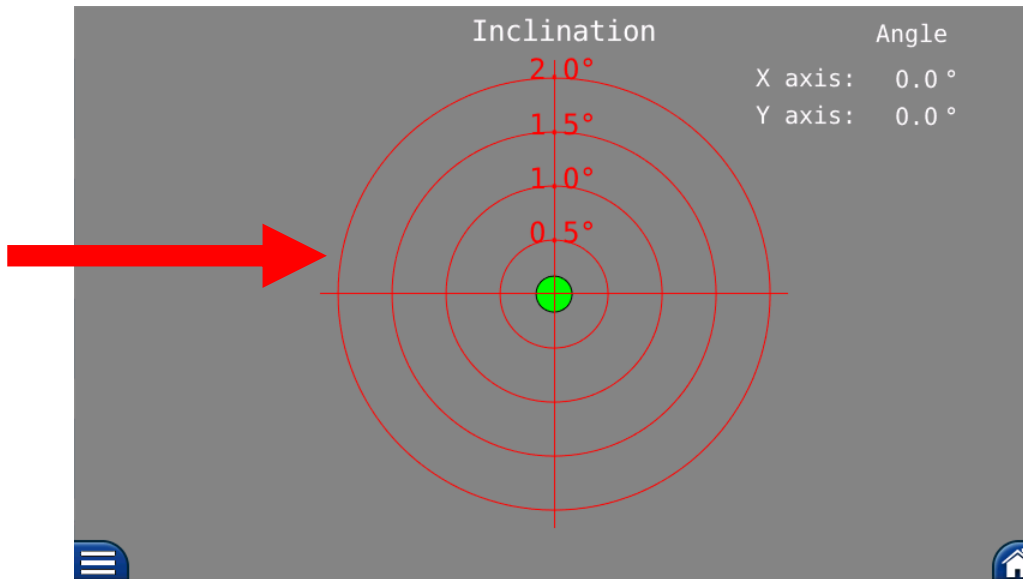

Frame-Level Screen

If the displays go red, indicating a problem with the Frame-Level sensor:

1. Check the cabling and connections between the sensor and the harness.
2. Replace the sensor.

20.0 Revision History

REVISION	DATE ISSUED	DESCRIPTION OF CHANGE(S)	REVISED BY	ER
0	8/23/2016	Initial Release	HK	16-869



11135 South James • Jenks, OK 74037
 Phone: (918) 298-8300
 Fax: (918) 298-8301

www.team-twg.com

Greer Company is a part of TWG.

As a leader in product innovation, Greer Company is committed to the ongoing improvement of its equipment.
 We reserve the right to make changes to our products without notice.

©2016 TWG. All rights reserved.